

Operation, Repair, Parts Airless Paint Line Striper



3A2702A

EN

For the application of line striping materials. For professional use only. For outdoor use only. Not for use in hazardous locations or explosive atmospheres.

Sure Stripe 4550, Sure Stripe 6050.

3300 psi (22.8 MPa, 228 bar) *Maximum Working Pressure*

See page 48 for model information, including maximum working pressure and approvals.



Important Safety Instructions

Read all warnings and instructions in this manual, related manuals, and on the equipment. Be familiar with the controls and the proper usage of the equipment. Save these instructions.

**Related Manuals - 312363 - 500 Gun
- 3A0479- 009 Gun**

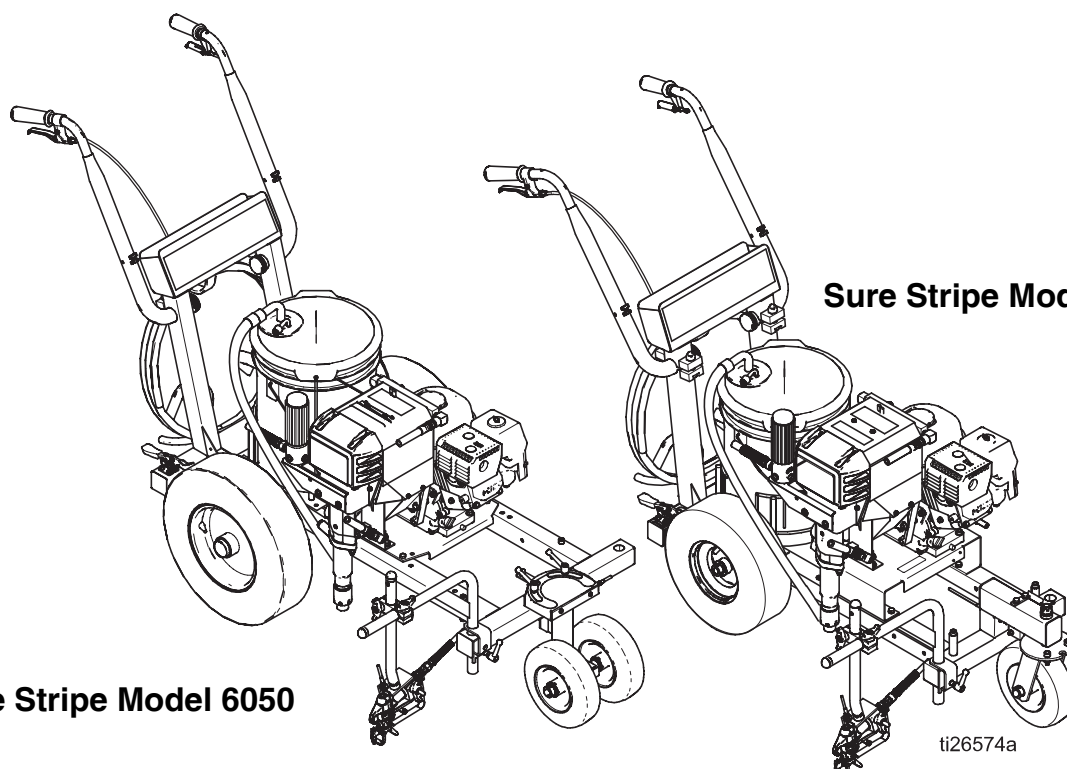

Sure Stripe Model 6050

Sure Stripe Model 4550

ti26574a







PROVEN QUALITY. LEADING TECHNOLOGY.

Contents





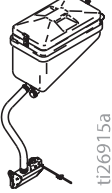
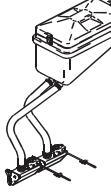

Models	3
Warnings	4
Uni-Tip Selection	7
Component Identification	8
Operation	9
Setup	9
Pressure Relief Procedure	10
Startup	11
Gun Operation	13
Clean-up	16
Handle Bar Adjustment	17
Maintenance	18
Striper	18
Gun	19
Troubleshooting	20
General Troubleshooting	20
Airless Spray Troubleshooting	23
Field Troubleshooting	24
Repair	25
Fluid Pump Servicing and Repair	25
Replacement of Electrical Control Board	30
Pressure Calibration of the Electrical Control Board	30
Clutch Replacement	33
Parts Lists	35
Pressure Control Wiring Diagrams	48
Technical Data	50
Airlessco Standard Warranty	51

Models

4550

							
305403	✓		✓		✓		
305404		✓	✓			✓	
865937	✓			✓	✓		
865938		✓		✓		✓	

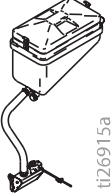
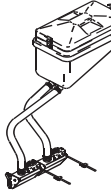
6050

							
305305	✓		✓	✓	✓		✓
305307		✓	✓	✓		✓	✓

Warnings

The following warnings are for the setup, use, grounding, maintenance, and repair of this equipment. The exclamation point symbol alerts you to a general warning and the hazard symbols refer to procedure-specific risks. When these symbols appear in the body of this manual or on warning labels, refer back to these Warnings. Product-specific hazard symbols and warnings not covered in this section may appear throughout the body of this manual where applicable.

WARNING



FIRE AND EXPLOSION HAZARD

Flammable fumes, such as solvent and paint fumes, in **work area** can ignite or explode. Paint or solvent flowing through the equipment can cause static sparking. To help prevent fire and explosion:



- Use equipment only in well ventilated area.
- Do not fill fuel tank while engine is running or hot; shut off engine and let it cool. Fuel is flammable and can ignite or explode if spilled on hot surface.
- Eliminate all ignition sources; such as pilot lights, cigarettes, portable electric lamps, and plastic drop cloths (potential static sparking).
- Ground all equipment in the work area. See **Grounding** instructions.
- Never spray or flush solvent at high pressure.
- Keep work area free of debris, including solvent, rags and gasoline.
- Do not plug or unplug power cords, or turn power or light switches on or off when flammable fumes are present.
- Use only grounded hoses.
- Hold gun firmly to side of grounded pail when triggering into pail. Do not use pail liners unless they are anti-static or conductive.
- **Stop operation immediately** if static sparking occurs or you feel a shock. Do not use equipment until you identify and correct the problem.
- Keep a working fire extinguisher in the work area.



CARBON MONOXIDE HAZARD

Exhaust contains poisonous carbon monoxide, which is colorless and odorless. Breathing carbon monoxide can cause death.

- Do not operate in an enclosed area.

! WARNING



SKIN INJECTION HAZARD

High-pressure spray is able to inject toxins into the body and cause serious bodily injury. In the event that injection occurs, **get immediate surgical treatment.**



- Do not aim the gun at, or spray any person or animal.
- Keep hands and other body parts away from the discharge. For example, do not try to stop leaks with any part of the body.



- Always use the nozzle tip guard. Do not spray without nozzle tip guard in place.
- Use Graco nozzle tips.



- Use caution when cleaning and changing nozzle tips. In the case where the nozzle tip clogs while spraying, follow the **Pressure Relief Procedure** for turning off the unit and relieving the pressure before removing the nozzle tip to clean.



- Equipment maintains pressure after power is shut off. Do not leave the equipment energized or under pressure while unattended. Follow the **Pressure Relief Procedure** when the equipment is unattended or not in use, and before servicing, cleaning, or removing parts.

- Check hoses and parts for signs of damage. Replace any damaged hoses or parts.

- This system is capable of producing 3000 psi. Use Graco replacement parts or accessories that are rated a minimum of 3000 psi.

- Always engage the trigger lock when not spraying. Verify the trigger lock is functioning properly.

- Verify that all connections are secure before operating the unit.

- Know how to stop the unit and bleed pressure quickly. Be thoroughly familiar with the controls.



EQUIPMENT MISUSE HAZARD





Misuse can cause death or serious injury.







- Do not operate the unit when fatigued or under the influence of drugs or alcohol.
- Do not exceed the maximum working pressure or temperature rating of the lowest rated system component. See **Technical Data** in all equipment manuals.
- Use fluids and solvents that are compatible with equipment wetted parts. See **Technical Data** in all equipment manuals. Read fluid and solvent manufacturer's warnings. For complete information about your material, request Safety Data Sheet (SDS) from distributor or retailer.
- Do not leave the work area while equipment is energized or under pressure.
- Turn off all equipment and follow the **Pressure Relief Procedure** when equipment is not in use.
- Check equipment daily. Repair or replace worn or damaged parts immediately with genuine manufacturer's replacement parts only.
- Do not alter or modify equipment. Alterations or modifications may void agency approvals and create safety hazards.
- Make sure all equipment is rated and approved for the environment in which you are using it.
- Use equipment only for its intended purpose. Call your distributor for information.
- Route hoses and cables away from traffic areas, sharp edges, moving parts, and hot surfaces.
- Do not kink or over bend hoses or use hoses to pull equipment.
- Keep children and animals away from work area.
- Comply with all applicable safety regulations.

Warnings

WARNING

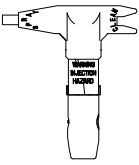
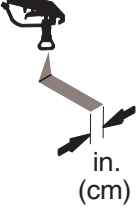
	<p>PRESSURIZED ALUMINUM PARTS HAZARD</p> <p>Use of fluids that are incompatible with aluminum in pressurized equipment can cause serious chemical reaction and equipment rupture. Failure to follow this warning can result in death, serious injury, or property damage.</p> <ul style="list-style-type: none">• Do not use 1,1,1-trichloroethane, methylene chloride, other halogenated hydrocarbon solvents or fluids containing such solvents.• Do not use chlorine bleach.• Many other fluids may contain chemicals that can react with aluminum. Contact your material supplier for compatibility.
 	<p>MOVING PARTS HAZARD</p> <p>Moving parts can pinch, cut, or amputate fingers and other body parts.</p> <ul style="list-style-type: none">• Keep clear of moving parts.• Do not operate equipment with protective guards or covers removed.• Pressurized equipment can start without warning. Before checking, moving, or servicing equipment, follow the Pressure Relief Procedure and disconnect all power sources.
	<p>TOXIC FLUID OR FUMES HAZARD</p> <p>Toxic fluids or fumes can cause serious injury or death if splashed in the eyes or on skin, inhaled, or swallowed.</p> <ul style="list-style-type: none">• Read SDS to know the specific hazards of the fluids you are using.• Store hazardous fluid in approved containers, and dispose of it according to applicable guidelines.
	<p>PERSONAL PROTECTIVE EQUIPMENT</p> <p>Wear appropriate protective equipment when in the work area to help prevent serious injury, including eye injury, hearing loss, inhalation of toxic fumes, and burns. This protective equipment includes but is not limited to:</p> <ul style="list-style-type: none">• Protective eye wear, and hearing protection.• Respirators, protective clothing, and gloves as recommended by the fluid and solvent manufacturer.
	<p>CALIFORNIA PROPOSITION 65</p> <ul style="list-style-type: none">• The engine exhaust from this product contains a chemical known to the state of California to cause cancer, birth defects or other reproductive harm. This product contains a chemical known to the State of California to cause cancer, birth defects or other reproductive harm. Wash hands after handling.

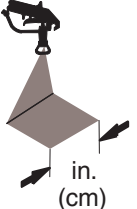
Uni-Tip Selection

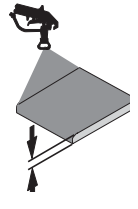
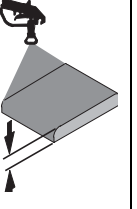
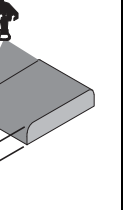
							
69215ST*	2 (5)				✓	✓	
69217ST		4 (10)				✓	
69315ST		6 (15)			✓		
69317ST		6 (15)			✓	✓	
69319ST		6 (15)				✓	
69321ST		6 (15)				✓	
69327ST		6 (15)					✓
69417ST			6-8 (15-20)		✓		
69517ST				10 (25)	✓		
69615ST*				12 (30)	✓		
69617ST				12 (30)		✓	
* Use 100 mesh filter to reduce tip clogs							

Component Identification

Component Identification

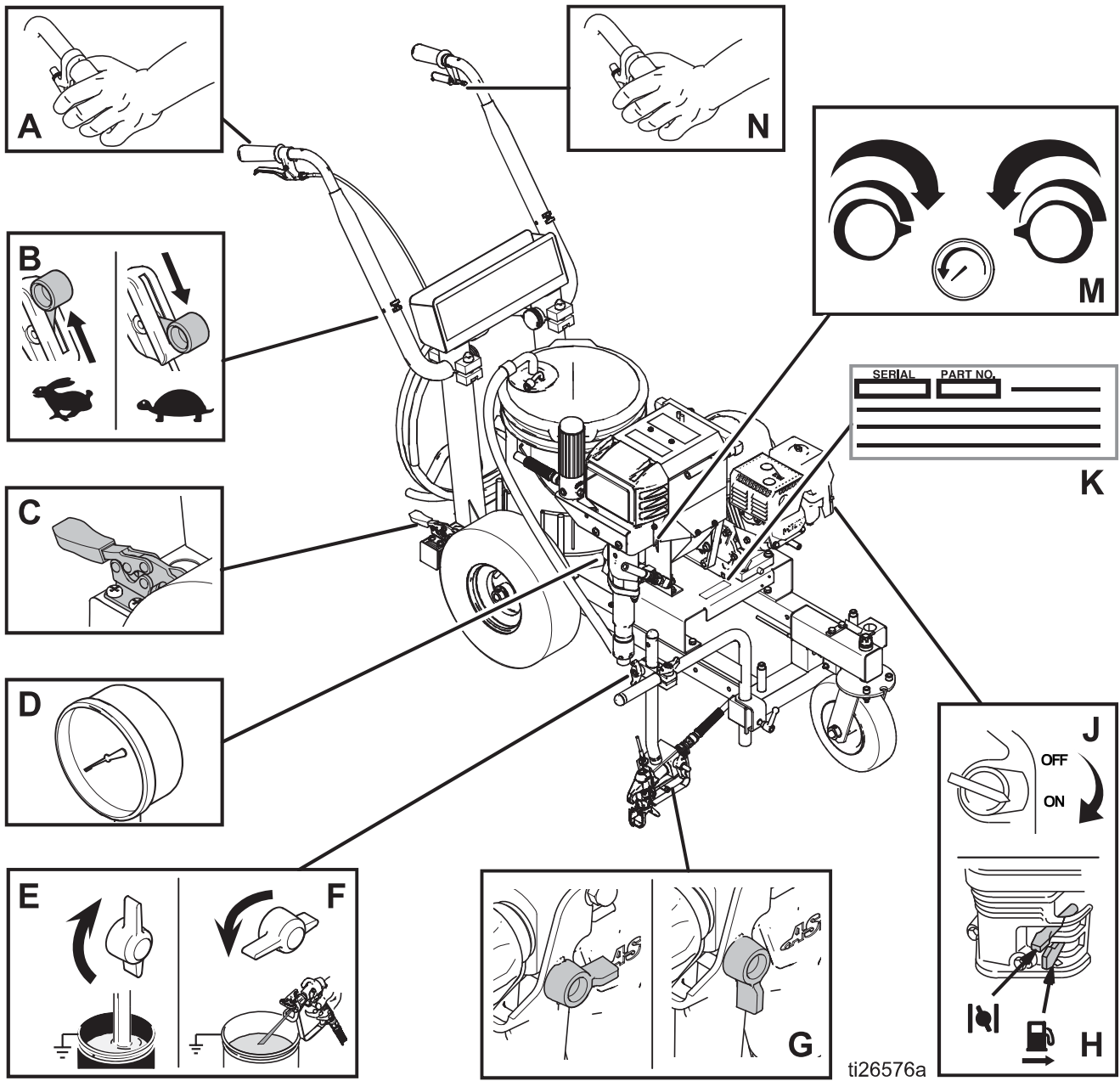

A	Spray Gun Control
B	Engine Throttle
C	Brake
D	Pressure Gauge
E	Prime Valve
F	Prime Valve
G	Gun Trigger Lock
H	Engine Controls
J	Engine ON/OFF Switch
K	Serial Identification Tag

M	Pressure Control
N	Turn Control

ti26576a

Operation

Setup



The equipment must be grounded to reduce the risk of static sparking. Static sparking can cause fumes to ignite or explode. Grounding provides an escape wire for the electric current.

1. Ground striper with grounding clamp during Setup and Cleanup.

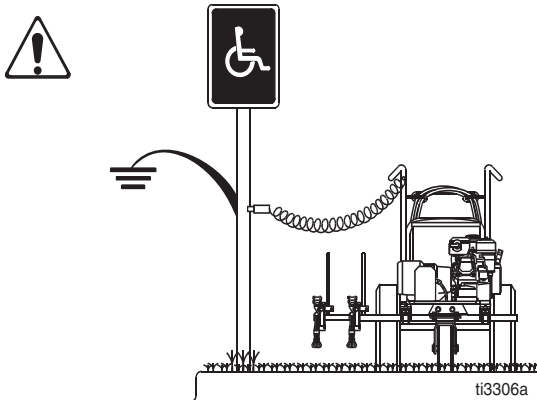

2. Each time you spray and store, add 3 to 5 drops of Throat Seal Oil (TSO) to decrease packing wear.

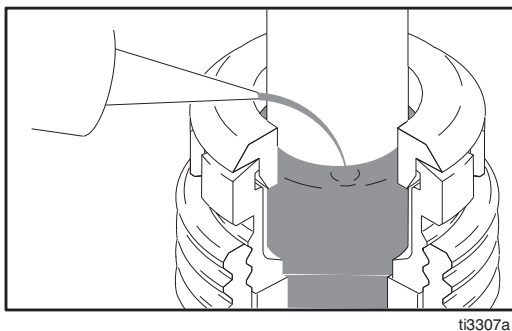

3. Check engine oil level. Add SAE 10W-30 (summer) or 5W-20 (winter). See engine manual.



4. Fill fuel tank.

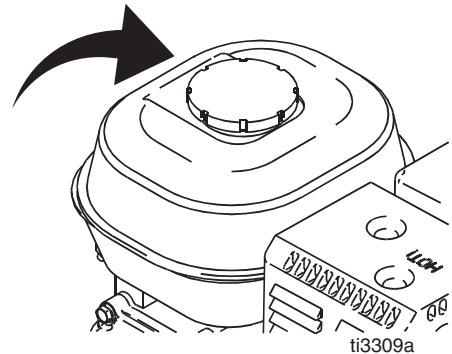

5. If removed, install strainer.

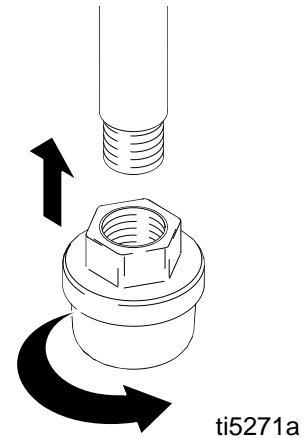

6. Open prime valve. Turn pressure control counterclockwise to lowest pressure.

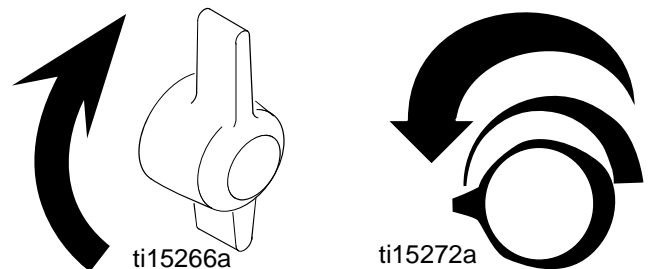

NOTE: Minimum hose size allowable for proper striper operation is 1/4 in. x 50 ft.

Operation

- Place siphon tube set in grounded metal pail partially filled with flushing fluid. Attach ground wire to pail and to true earth ground. Do 1. - 5. of **Startup** to flush out storage oil shipped in striper. Use water to flush water-base paint and mineral spirits to flush oil-base paint and storage oil.

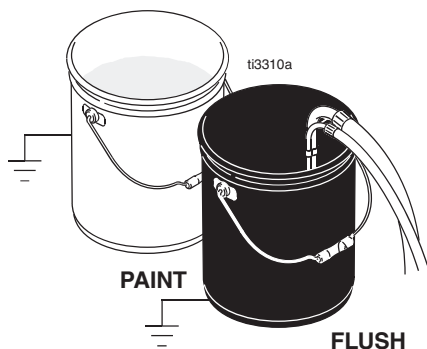

- Ground striper with grounding clamp.

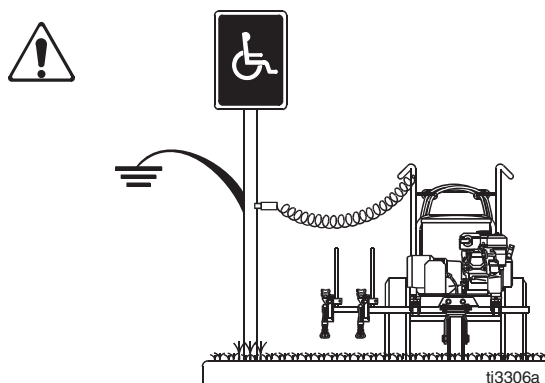

- Turn engine **OFF**.

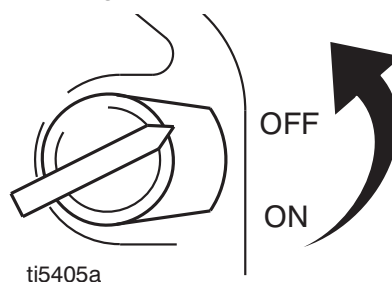

- Turn pressure to lowest setting. Trigger gun to relieve pressure.

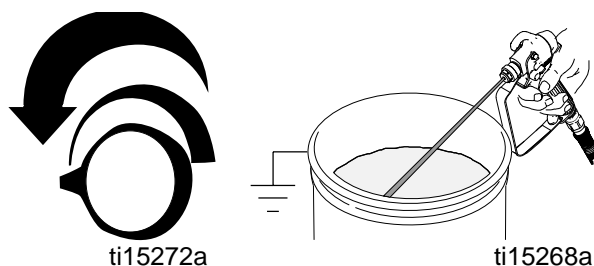

- Engage gun trigger lock. Open prime valve.

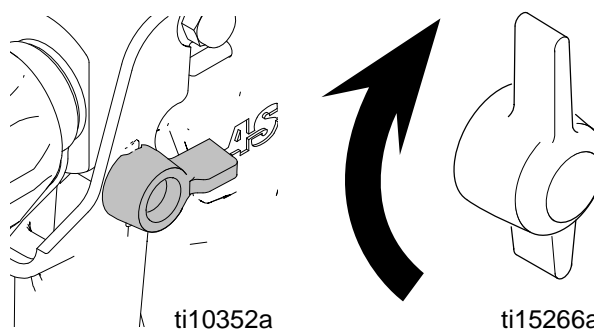

If you suspect that the Uni-Tip or hose is completely clogged, or that pressure has not been fully relieved after following the steps above, **VERY SLOWLY** loosen Uni-Tip Guard retaining nut or hose end coupling to relieve pressure gradually, then loosen completely. Then clear tip or hose.

Pressure Relief Procedure



Follow the **Pressure Relief Procedure** whenever you see this symbol.

This equipment stays pressurized until pressure is manually relieved. To help prevent serious injury from pressurized fluid, such as skin injection, splashed fluid and moving parts, follow the **Pressure Relief Procedure** whenever sprayer is stopped and before sprayer is cleaned or checked, and before equipment is serviced.

Startup

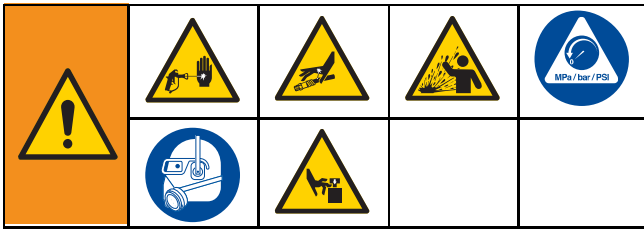

1. Perform Pressure Relief Procedure. See **Pressure Relief Procedure**, page 10.
2. Start Engine.
 - a. Move fuel valve to open.



- b. Move choke to closed.

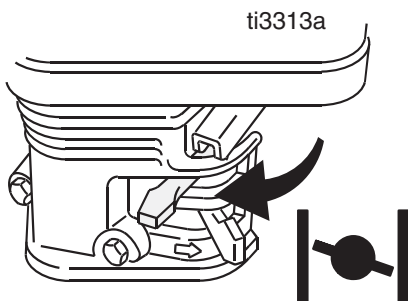

- c. Set throttle to fast.

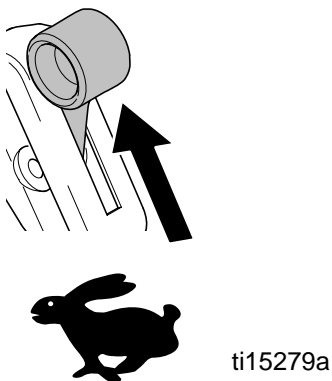

- d. Set engine switch ON.

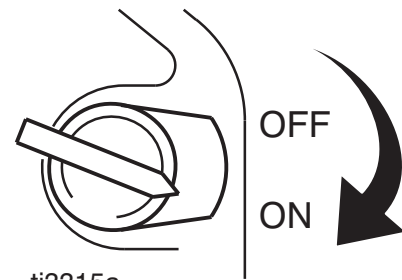

- e. Pull starter cord.

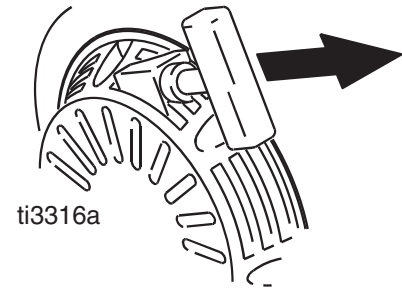

- f. After engine starts, move choke to open.

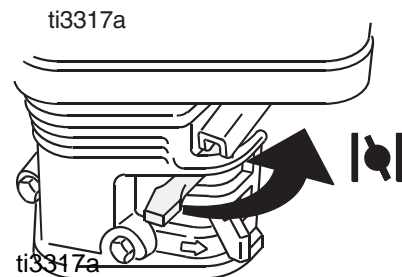

- g. Set throttle to desired setting.

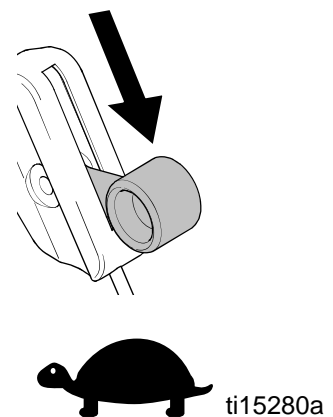

Operation

3. Increase pressure enough to start pump. Allow fluid to circulate for 15 seconds.



15 SEC.

6. Place siphon tube in paint pail.

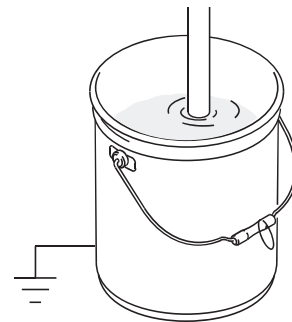

PAIN**T**

4. Turn pressure down, close prime valve. Disengage gun trigger lock.

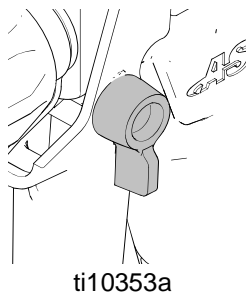
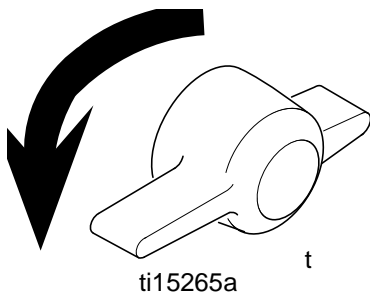

7. Trigger gun again into flushing fluid pail until paint appears. Assemble Uni-Tip and Uni-Tip Guard.

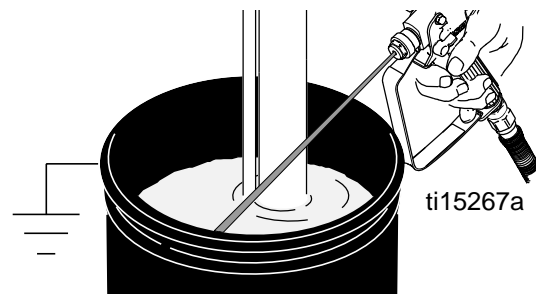

FLUSH

5. Hold gun against grounded metal flushing pail. Trigger gun and increase fluid pressure slowly until pump runs smoothly.

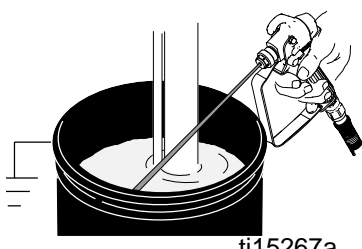



FLUSH



Inspect fittings for leaks. Do not stop leaks with your hand or a rag! If leaks occur, turn striper OFF immediately. Perform **Pressure Relief** (page 10). Tighten leaky fittings. Repeat **Startup**, steps 1-2. If no leaks, continue to trigger gun until system is thoroughly flushed. Proceed to step 3.



Gun Operation

Gun Trigger Lock

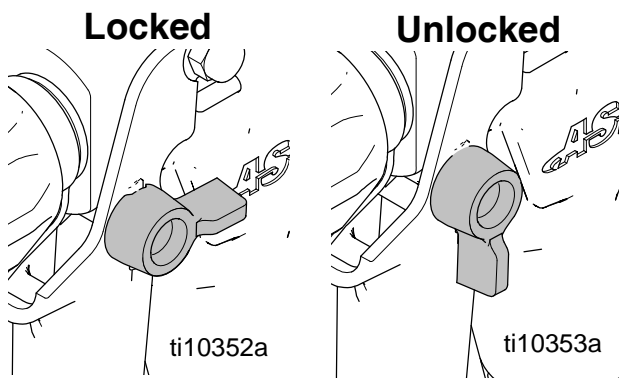
				
<p>Always engage the trigger lock when the sprayer is stopped to prevent the gun from being triggered accidentally by hand or if dropped or bumped.</p>				



Setup

				
<p>Make sure striper is turned off.</p>				

Connect Gun to Striper

1. Attach supply hose to striper fluid outlet.
2. Attach other end of supply hose to gun swivel. Use two wrenches (one on the swivel and one on the hose) to tighten all connections securely.

Uni-Tip and Uni-Tip Guard Assembly

1. Engage trigger lock. Use end of Uni-Tip (A) to press Uni-Tip Seal (B) into Uni-Tip Guard (D), with curve matching tip bore (C).

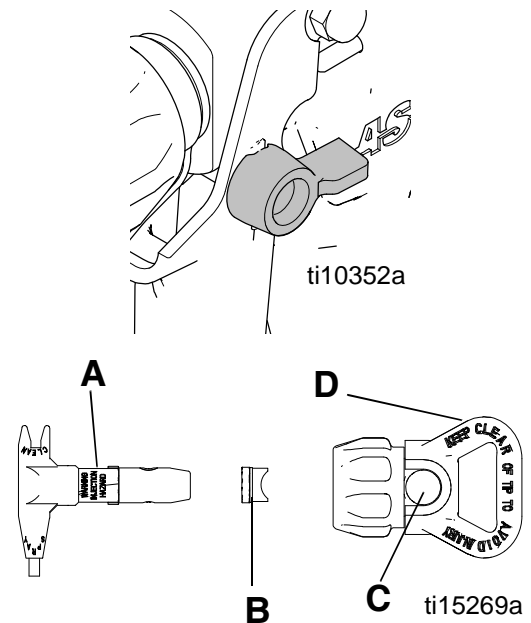

2. Insert Uni-Tip in tip bore and firmly thread assembly onto gun.

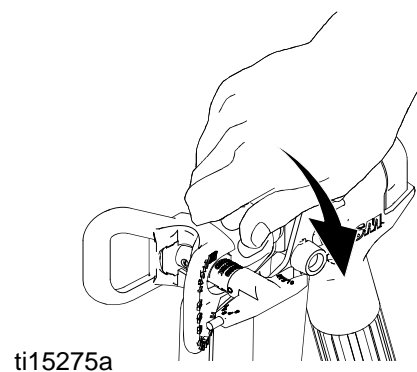
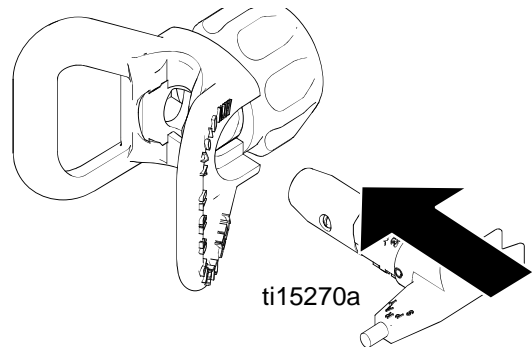

Operation

Gun Placement

1. **Install Gun:** Insert gun into gun holder with head guard pressed against the holder assembly bracket.

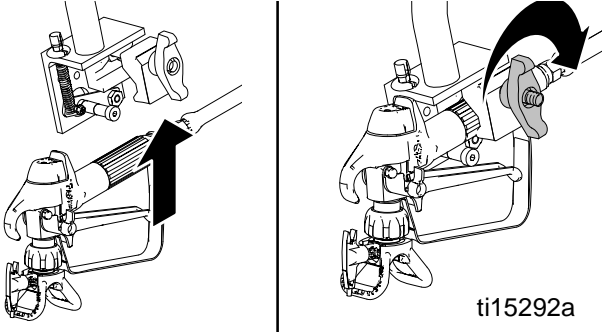

2. Tighten gun into clamp.

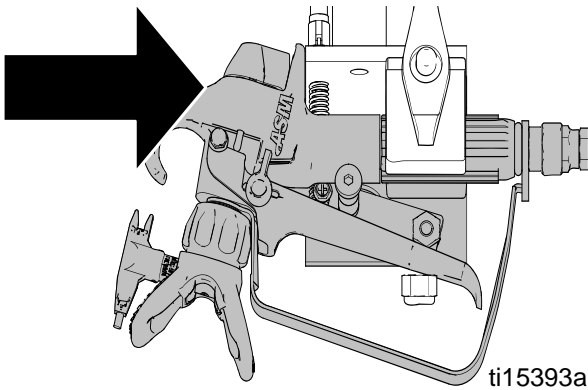

3. **Position Gun:** Up/down, forward/reverse, left/right.

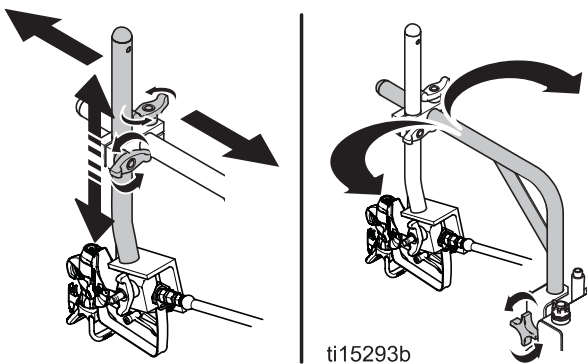

NOTE: Verify that the gun can still be triggered **and** that the trigger lock can still be engaged after installation. Make adjustments if necessary.

Clearing Tip Clogs



1. Release trigger, engage gun trigger lock. Rotate Uni-Tip. Disengage gun trigger lock and trigger gun to clear the clog.

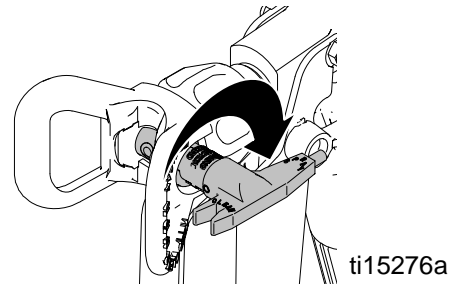

2. Engage gun trigger lock, return Uni-Tip to original position, disengage gun trigger lock and continue spraying.

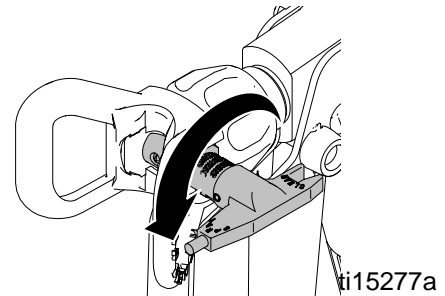

Spraying Gun



1. Disengage trigger lock.
2. Be sure the arrow-shaped tip faces forward (spray).
3. Hold gun perpendicular and approximately 12 in. (304 mm) from surface. Move gun first, then pull trigger to spray a test pattern.
4. Slowly increase pump pressure until coverage is uniform and even (see striper instruction manual for additional information).

Aligning Spray

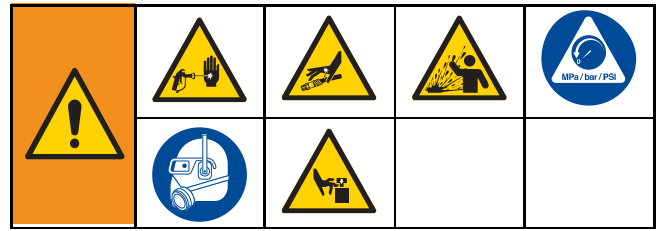

1. Perform Pressure Relief Procedure. See **Pressure Relief Procedure**, page 10. Engage trigger lock.
2. Loosen guard and retaining nut.
3. Align guard horizontally to spray a horizontal pattern, vertically to spray a vertical pattern.

Horizontal

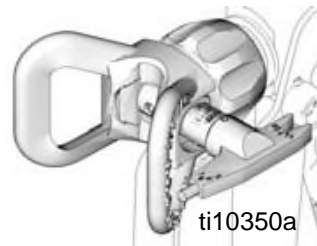

Vertical

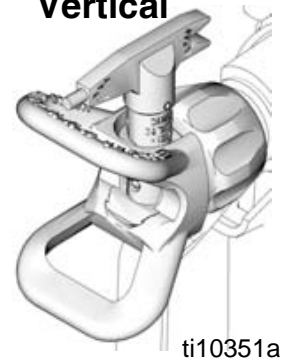

Cleanup

Flush gun after each work shift and store in a dry location. Do not leave the gun or any parts in water or cleaning solvents.

Operation

Clean-up

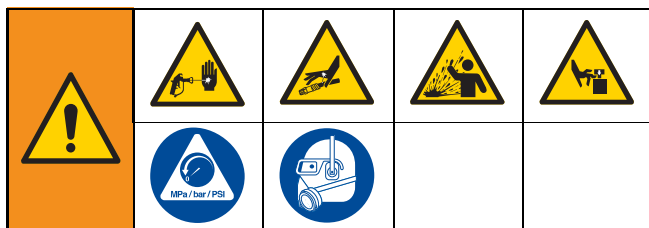

Perform Pressure Relief Procedure.
See **Pressure Relief Procedure**, page 10.

1. Remove Uni-Tip Guard and Uni-Tip.

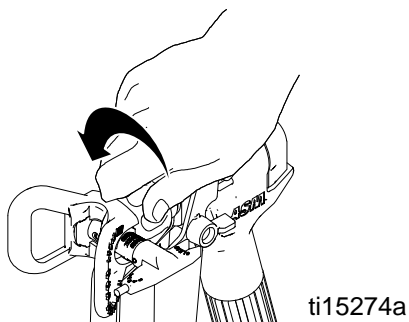

2. Clean gun filter, Uni-Tip Guard and Uni-Tip in flushing fluid.



FLUSH

3. Remove siphon tube set from paint and place in flushing fluid. Use water or pump conditioner for water-base paint and mineral spirits for oil-base paint.

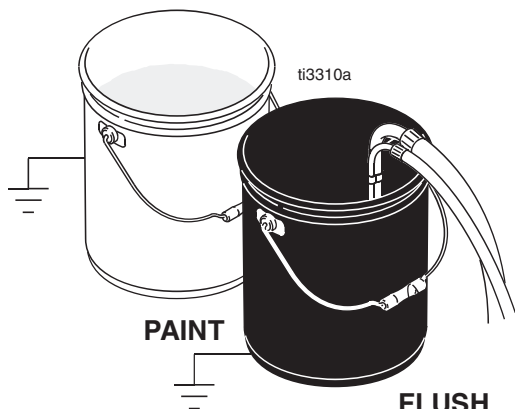

4. Turn engine **ON** and start engine.

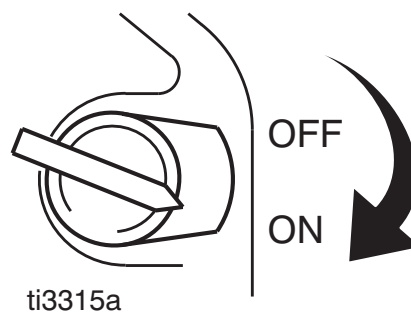

5. Close prime valve.

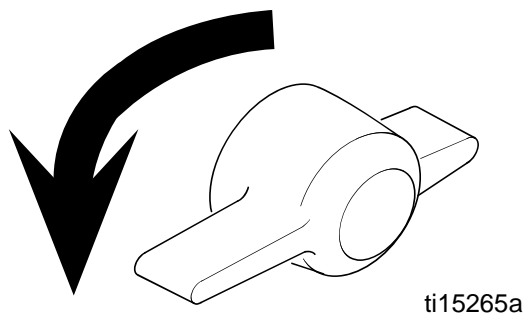

6. Hold gun against paint pail. Disengage gun trigger lock. Gradually turn pressure control up until motor begins to drive pump. Trigger gun until flushing fluid appears.

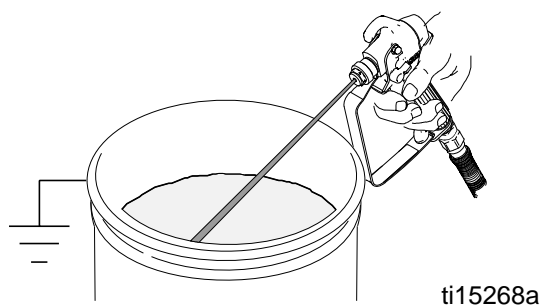

7. Move gun to flushing pail, hold gun against pail, trigger gun to thoroughly flush system. Release trigger and engage trigger lock.

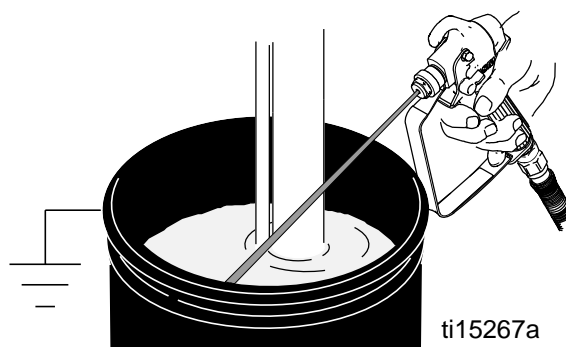

8. Open prime valve and allow flushing fluid to circulate for 1 to 2 minutes to clean drain tube.

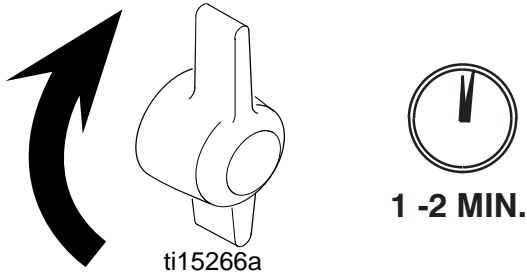

9. Raise siphon tube above flushing fluid and run striper for 15 to 30 seconds to drain fluid.

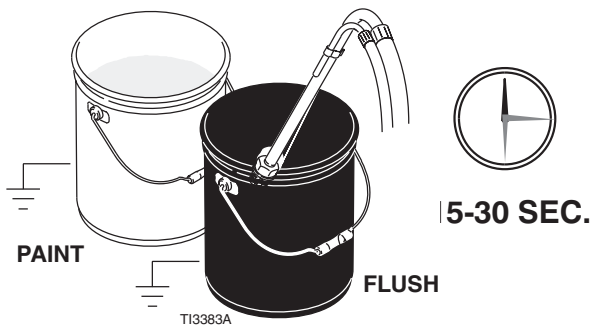

10. Turn engine **OFF**.

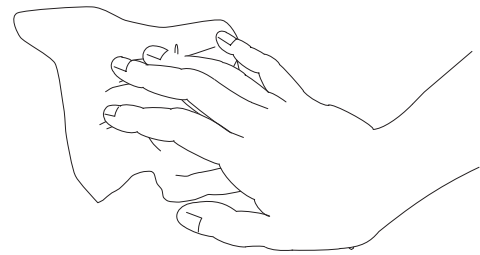
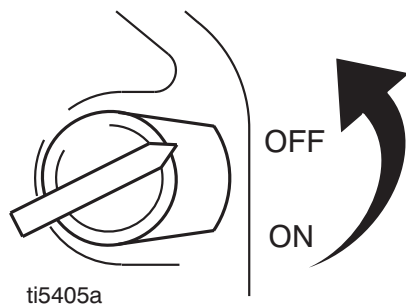

TI3388A

12. Clean Uni-Tip, Uni-Tip Guard and gasket with a soft bristle brush to prevent part failure due to dried materials. Assemble parts and attach loosely onto gun.



Handle Bar Adjustment

To adjust height and angle of handle bars, loosen two nuts (147) and move handle bars to desired position. Then tighten two nuts (147).

NOTE: Handle bars can be moved to down position for storage.

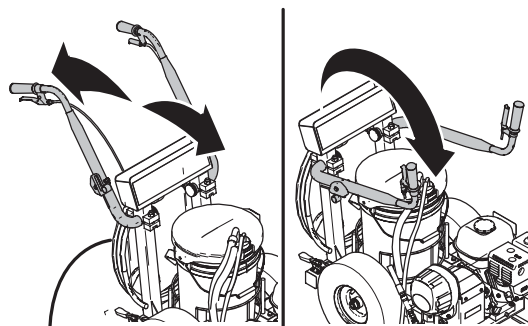

ti22122b

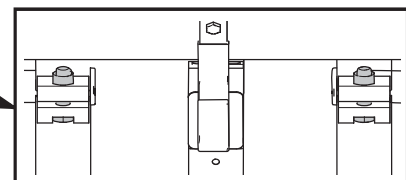

NOTICE

If flushing with water, flush again with pump conditioner to leave a protective coating to prevent freezing or corrosion.

11. Wipe striper, hose and gun with a rag soaked in water or mineral spirits.

Maintenance

Striper

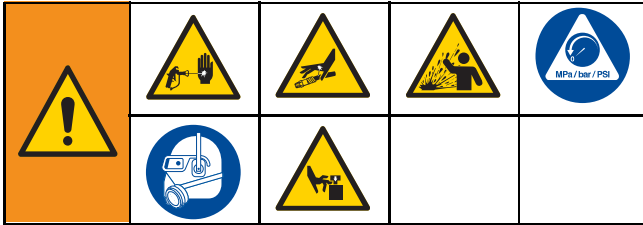

This equipment stays pressurized until pressure is manually relieved. To help prevent serious injury from pressurized fluid, such as skin injection, splashed fluid and moving parts, follow the **Pressure Relief Procedure** whenever sprayer is stopped and before sprayer is cleaned or checked, and before equipment is serviced.

NOTE: Minimum hose size allowable for proper striper operation is 1/4 in. x 50 ft. For detailed engine maintenance and specifications, refer to separate engine manual supplied.

DAILY: Check engine oil level and fill as necessary.

DAILY: Check hose for wear and damage.

DAILY: Check gun trigger lock for proper operation.

DAILY: Check pressure drain valve for proper operation.

DAILY: Check and fill gas tank.

AFTER THE FIRST 20 HOURS OF

OPERATION: Drain engine oil and refill with clean oil. See engine manual for correct oil viscosity.

WEEKLY: Remove air filter cover and clean element. Replace element if necessary. If operating in an unusually dusty environment, check air filter daily and replace if necessary. Replacement elements can be purchased from your local engine dealer.

WEEKLY: Check level of TSO in fluid pump packing nut. Add 3 to 5 drops if necessary. Keep TSO in nut to help prevent fluid buildup on piston rod and premature wear of packings.

AFTER EACH 100 HOURS OF

OPERATION: Change engine oil. See engine manual for correct oil viscosity.

SPARK PLUG: Use only BPR6ES (NGK) or W20EPR-U (NIPPONDENSO) plug. Gap plug to 0.028 to 0.031 in. (0.7 to 0.8 mm). Use spark plug wrench when installing and removing plug.

Swivel Wheel

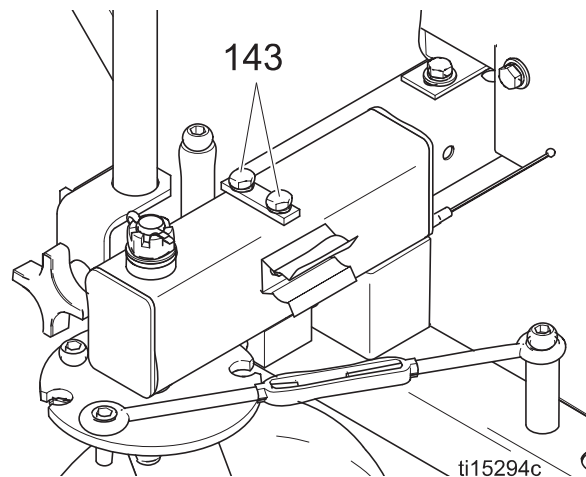

- Stripers are factory aligned, but if necessary, loosen two bolts (143) on swivel wheel assembly just enough to be able to move the wheel by hand.
- Place turnbuckle over the two mounting nubs on the frame.
- Pressurize the unit with water and Pump Conditioner and spray out several lines with the swivel assembly in the locked position. Use the turnbuckle to fine tune the alignment of the wheels until the stripes are straight.
- Tighten bolts (143).

Curves and Arcs

- The swivel assembly can be adjusted to 30 degrees either side of straight ahead. Place turnbuckle over mounting nubs. Adjust to the desired arc and tighten jam nuts. If you have arcs that you paint regularly, purchase additional turnbuckles (74) and keep them set to those arc sizes.

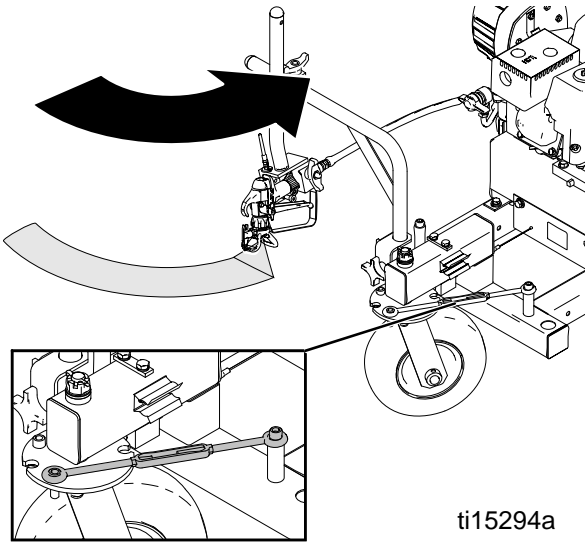

ti15294a

Pump

- Always stop the pump at the bottom of its stroke when you take a break or at the end of the day. This helps keep material from drying on the rod, damaging the packings.
- Keep the displacement pump packing nut/wet cup 1/3 full of Throat Seal Oil (2501) at all times. The TSO helps protect the packings and rod.
- Lubricate Connecting Rod Pin every three months.
- Inspect the packing nut daily. The paint pump has a patented "Triple Life Packing System". Packing life will be extended significantly if the proper packing tightening procedure is followed.

PACKING TIGHTENING PROCEDURE:

Inspect the packing nut daily. If seepage of paint into the packing nut and/or movement of the piston upward is found (while not spraying), the packing nut should be tightened enough to stop leakage only, but not any tighter. (Approximately 24 In lbs).

NOTICE

Do NOT over-tighten packings. Packings will become damaged and reduce the packing life.

Grease Points

- Fill grease points at swivel wheel until grease purges from end. Wipe away any excess grease. Use only quality-grade water resistant grease.

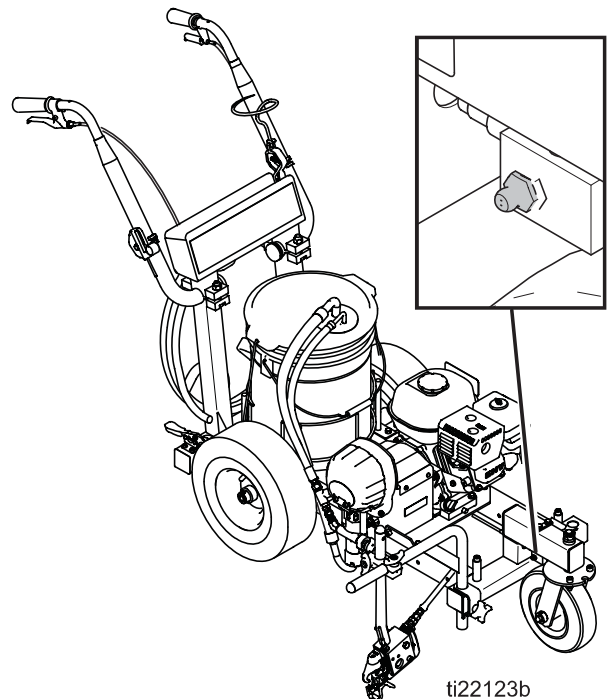

ti22123b

Gun

Refer to the 312363 Gun Manual for gun maintenance procedures.

Troubleshooting

General Troubleshooting

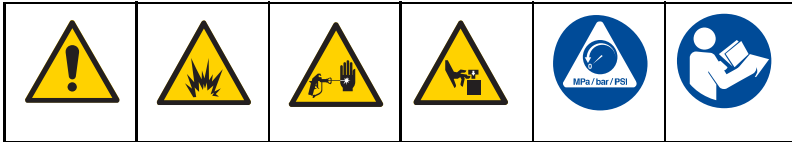

Problem	Cause	Solution
Engine Will Not Start	Engine switch is OFF	Turn engine ON
	Engine is out of gas	Refill gas tank (see engine manual).
	Engine oil level is low	Try to start engine. Replenish oil if necessary (see engine manual).
	Spark plug cable is disconnected or damaged	Connect spark plug cable or replace spark plug.
	Cold engine	Use choke.
	Fuel shut-off lever is OFF	Move lever to ON position.
	Oil is seeping into combustion chamber	Remove spark plug. Pull starter 3 to 4 times. Clean or replace spark plug. Start engine. Keep striper upright to avoid oil seepage.

Problem	Cause	Solution
Engine operates, but fluid pump does not operate	Pressure setting is too low	Turn pressure adjusting knob clockwise to increase pressure
	Uni-Tip or gun filter is clogged	Clean Uni-Tip or gun filter (see gun manual).
	Fluid pump piston rod is stuck due to dried paint	Repair pump (see pump manual).
	Connecting rod is worn or damaged	Replace connecting rod.
	Electrical power is not energizing clutch field.	<p>Check wiring connections, See pressure control repair, page 31.</p> <p>Test sensor by reading resistance between the red and black wires. The resistance runs between 1.5-3k Ohms.</p> <p>Have pressure control checked by authorized Pioneer dealer.</p>
	Clutch is worn, damaged, or incorrectly positioned.	Replace clutch, page 34.

Troubleshooting

Problem	Cause	Solution
Pump output is low	Piston ball is not seating	Service piston ball. See pump manual.
	Piston packings are worn or damaged	Replace packings. See pump manual.
	O-ring in pump is worn or damaged	Replace o-ring. See pump manual.
	Worn, missing, or improperly installed parts in suction nut	Remove suction nut and check that all parts are present and installed correctly.
	Engine speed is too low	Increase throttle setting. See Startup , page 11.
	Clutch is worn or damaged	Replace clutch, page 34.
	Pressure setting is too low	Increase pressure. See Startup , page 11.
	Uni-Tip filter or tip is clogged or dirty	See gun manual.
	Large pressure drop in hose with heavy materials	Use larger diameter hose and/or reduce overall length of hose. Use of more than 100 ft of 1/4 in. hose significantly reduces performance of striper. Use 1/4 in. hose for optimum performance (50 ft minimum).
Excessive paint leakage into throat packing nut	Throat packing nut is loose	See pump manual.
	Throat packings are worn or damaged	Replace packings. See pump manual.
	Fluid rod is worn or damaged	Replace rod. See pump manual.
Fluid is spitting from gun	Air in pump or hose	Check and tighten all fluid connections. Reprime pump.
	Uni-Tip is partially clogged	Clear Uni-Tip. See gun manual.
	Fluid supply is low or empty	Refill fluid supply. Reprime pump. Check fluid supply often to prevent running pump dry.

Problem	Cause	Solution
Pump is difficult to prime	Air in pump or hose	Check and tighten all fluid connections. Reduce engine speed and cycle pump as slowly as possible during priming.
	Suction nut is leaking	Clean suction nut. Be sure ball seat is not nicked or worn and that ball seats well. Reassemble suction nut.
	Pump packings are worn	Replace pump packings. See pump manual.
	Paint is too thick	Thin the paint according to supplier recommendations
	Engine speed is too high	Decrease throttle setting before priming pump.
High Engine Speed at no load	Incorrect throttle setting	Adjust throttle cable as needed
	Worn engine governor	Replace or service engine governor

Airless Spray Troubleshooting

Problem	Cause	Solution
Coarse spray	Low pressure	Increase pressure
Excessive fogging (overspray)	High pressure Material too thin	Reduce pressure to satisfactory pattern distribution. Use less thinner.
Pattern too wide	Spray angle too large	Use smaller spray angle Uni-Tip
Pattern too narrow	Spray angle too small	Use larger spray angle Uni-Tip (if coverage is acceptable, try tip in same nozzle group)
Too much material	Nozzle too large Material too thin Pressure too high	Use smaller nozzle Reduce pressure
Too little material	Nozzle too small	Use next larger nozzle Material too thick
Thin distribution in center of pattern "horns"	Worn Uni-Tip Wrong Uni-Tip	Change to new Uni-Tip Use nozzle with narrow spray angle
Thick skin of work	Material too viscous Application too heavy	Thin cautiously Reduce pressure and/or use Uni-Tip in next smaller nozzle group
Coating fails to close and smooth over	Material too viscous	Thin cautiously
Spray pattern irregular, deflected	Orifice clogged Uni-Tip damaged	Clean carefully Replace with new Uni-Tip
Craters or pock marks, bubbles on work	Solvent balance	Use 1 to 3% "short" solvents remainder "long" solvents (this is most likely to happen with material of low viscosity, lacquers, etc).
Clogged gun screens	Extraneous material in paint Coarse pigments Poorly milled pigments (paint pigments glocculate)	Clean screen. Use coarse screen if orifice size allows. Use courser screen with larger orifice tips. Obtain ball milled paint. If thinner has been added, test to see if a cover screen. Incompatible drop placed on top of paint mixes or flattens out on the paint mixture and thinners on the surface. If not, try different thinner in fresh batch of paint.

Field Troubleshooting

Problem	Cause	Solution
Striper will not prime	Air leak due to: <ul style="list-style-type: none"> • Loose suction nut • Worn o-rings • Hole in siphon hose • Stuck or fouled balls 	<ul style="list-style-type: none"> • Tighten suction nut • Replace o-ring on suction seat • Replace siphon hose. See pump manual
Striper primes but has poor or no pressure	<ul style="list-style-type: none"> • Pressure set too low • Filter is clogged • Outlet valve fouled/worn • Prime/pressure valve bypassing • Packings and/or piston worn 	<ul style="list-style-type: none"> • Turn up pressure • Clean or replace gun filter • Service outlet valve • Clean or replace prime valve • Tighten packing nut with tool • Repack unit
Unit does not maintain good spraying pressure	<ul style="list-style-type: none"> • Blown Uni-Tip • Packings and/or pistons worn • Upper seat worn 	<ul style="list-style-type: none"> • Replace Uni-Tip • Repack striper • Replace upper seat and ball
Clutch does not engage	Clutch failed. Check resistance between leads (should read between .6 -.7k Ohms).	Take to Pioneer Service Center
	Engine voltage is below 19-24 VAC	Take to Honda Engine Service Center
	Pressure Sensor Check 1.5 - 3.5k Ohms	Replace the sensor

Repair

Servicing the Fluid Pump

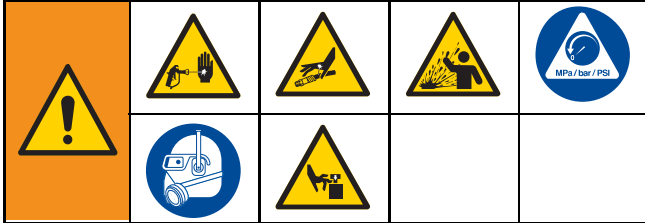

This equipment stays pressurized until pressure is manually relieved. To help prevent serious injury from pressurized fluid, such as skin injection, splashed fluid and moving parts, follow the **Pressure Relief Procedure** whenever sprayer is stopped and before sprayer is cleaned or checked, and before equipment is serviced.

Fluid Pump Disconnect

1. Flush the material you are spraying.
2. **Relieve Pressure**, see page 10. Stop the pump in the middle of down stroke.
3. Remove the suction tube and fluid hose (if so equipped) from the fluid pump.
4. Remove the connecting rod shield from the pump.
5. Remove two retaining rings (100) and slip the sleeve of the coupling down and remove both coupling halves. This will disconnect fluid pump from the connecting rod.
6. Using a 7/8" box wrench disconnect the high pressure fluid line from the pump.

7. Using a 9/16" wrench, unscrew the two tie rod lock-nuts (18).
8. Pull the pump off the tie rods.

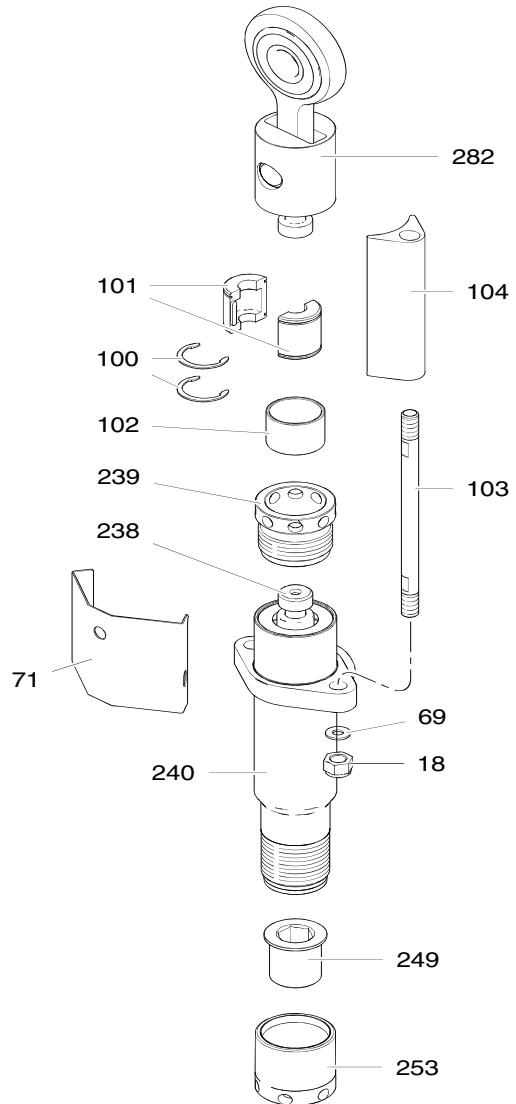

Fluid Pump Reinstall

1. Loosen the packing nut and extend piston rod to fully up position.

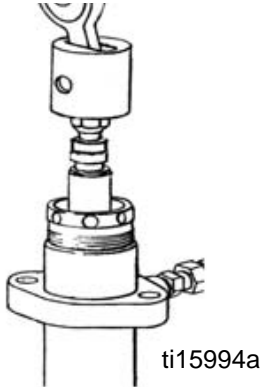

2. Insert one of the retaining rings through the packing nut and rest the sleeve on top of it.

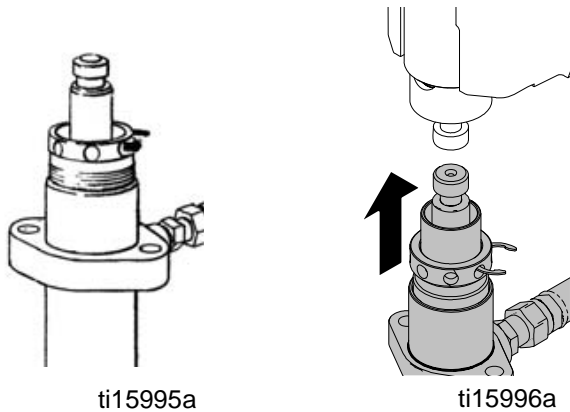

3. Connect the connecting rod with the fluid pump by installing the coupling halves. Slide sleeve over the coupling halves and secure with retaining ring.

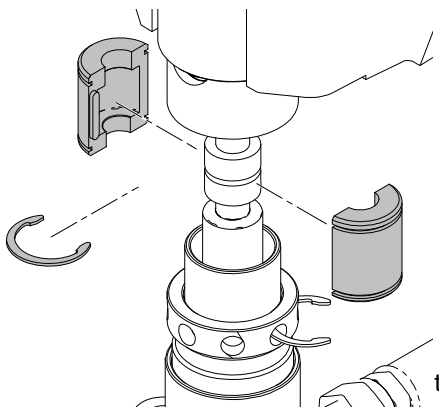

4. Remove the retaining ring from the packing nut and insert into coupling halves.

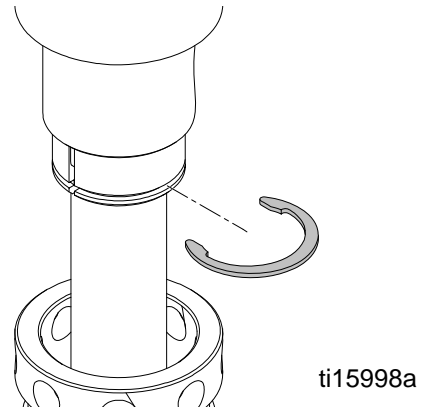

5. Secure the fluid pump housing to the tie rods and screw lock nuts with washers on loosely.
6. Tighten the tie rod lock nuts evenly to 30 ft. lb.

NOTE: After all the rod lock nuts are tight, the alignment of both rods should allow easy assembly and disassembly of the coupling. If any binding, loosen and re-tighten all the rod lock nuts to improve the alignment. Misalignment causes premature wear of seal and packings.

7. Tighten packing nut clockwise until resistance against the packings can be felt. Turn it one full turn more.
8. Start the pump and operate it slowly (at low engine speed) to check the piston rod for binding. Adjust tie rod lock nuts if necessary to eliminate binding.
9. Prime the unit and run at maximum pressure for several minutes, then release the pressure and repeat step 7.
10. Fill the wet cup (packing nut) with five drops of TSO (Throat Seal Oil).

Servicing the Inlet and Outlet Valves

Disassembly of the Outlet Valve

1. Using the rod collar tool (189211), screw the suction nut (253), containing intake seat support, off of the fluid body.
2. Remove the inlet seat (250), O-ring, inlet ball (248) and inlet retainer (247) with O-ring.
3. Clean all parts and inspect them for wear and damage, replacing parts as needed. Old O-rings should be replaced with new ones.

NOTE: Inlet Seat (867574) is reversible.

4. Clean inside of fluid body.
5. Reassemble the valve and screw it onto the fluid body if no further service is needed.

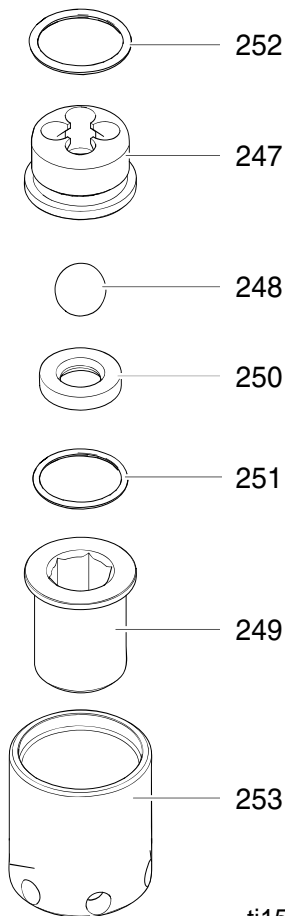

Servicing the Outlet Valve

1. Complete all steps of the Fluid Pump Disconnect, page 26.
2. Screw the suction nut off the pump and remove inlet valve assembly.
3. Using the rod collar tool, loosen the packing nut and push the piston (238) down and out of the fluid body.
4. Place piston holder (866058) in a vise. Slide piston (238) into holder and lock in place with a 1/4" pin (867166).
5. Clean all parts and inspect them carefully for wear or damage. Inspect the outside of the piston rod for scoring or wear. Replace these parts if needed. A worn piston rod will cause premature wear of packings.
6. Using 3/8" allen wrench to unscrew retainer (246) from piston (238).
7. Remove outlet seat (245), O-ring, outlet ball (244) and outlet retainer (243).
8. Inspect outlet ball (244) and seat for wear. Replace as required.

NOTE: Outlet Seat (867575) is reversible.

- Install parts back into piston rod. Place two drops of Loctite No. 242 (blue) on threads of the retainer (246) before assembling and torque to 20 ft-lbs.

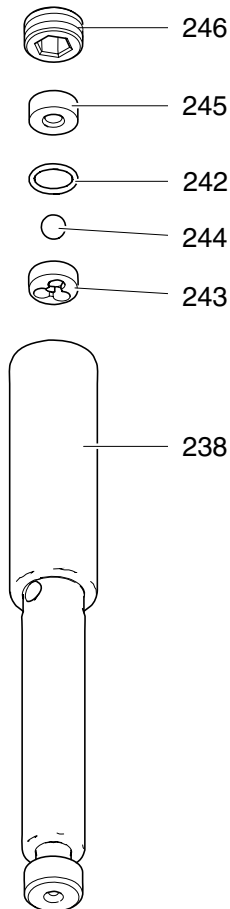

ti16000b

Packing Replacement Procedures

Disassembly of the Fluid Pump

- Unscrew and remove the packing nut.
- Push the piston rod down through the packings and out of the pump.
- Now push the packing removal tool up through the pump and remove the top bringing the packings, spacer and springs along with it, leaving the fluid body empty.

NOTE: Make sure all packings and glands have been removed from the fluid pump.

- Clean inside of fluid body.

- Disassemble all parts and clean for reassembly. Discard any old packings. Save the metal upper glands. Replace metal lower glands with new metal glands from the packing kit.

NOTE: If the old packing had a metal gland, discard and replace with a new plastic one from packing kit.

- Lubricate leather packing in lightweight oil for 10 minutes prior to reassembly.
- Unscrew and remove the packing nut.
- Push the piston rod down through the packings and out of the pump.
- Now push the packing removal tool up through the pump and remove from the top bringing the packings, spacer and springs along with it, leaving fluid body empty.

NOTE: Make sure all old packings and glands have been removed from fluid pump.

Reassembly of the Fluid Pump

- Take the lower metal male gland and place it down on the flat side.
- Take three of the lower polyethylene V-packings and two of the leather V-packings and place onto the male gland, with the inverted side down, in the following order:
 - Polyethylene
 - Leather
 - Polyethylene
 - Leather
 - Polyethylene
- Take the female adapter, which is inverted on both sides, and place it on top of the assembled lower packings.
- Follow step 2 above, but with the packings inverted side up.
- Take the second lower male gland and place it on top of the assembled packings with the rounded side down.

6. Take the assembled glands and packings (13 pieces all together) and slide on to the lower half of the piston.
 7. Take the spacer and slide over the top of the piston (it doesn't matter which direction it sits).
 8. Take the three Belleville Springs and slide over the top of the piston in the following order:
 - First spring, curve facing down
 - Second spring, curve facing up
 - Third spring, curve facing down
 9. Take the upper male gland and place it rounded side up.
 10. Take the three upper polyethylene V-packings and two leather packings and assemble with the inverted side down on to the male gland in the following order:
 - Polyethylene
 - Leather
 - Polyethylene
 - Leather
 - Polyethylene
 11. Take the upper female gland and place on top of the assembled upper packings with the inverted side down.
 12. Take the assembled upper glands and packings (7 pieces) and slide over the top of the piston, making sure the inverted sides are facing down.
 13. Take the V-packing holder and replace the white O-ring and the black O-ring with new ones from the packing kit.
 14. Slide the V-packing holder over the top of the upper packings so they fit inside.
 15. Lubricate the inside of the fluid pump body and the outside of the packings with a lightweight oil.
 16. Slide the completed assembly into the fluid pump body.
- NOTE:** To keep packings secured in the correct position, hold the pump body upside down and push the completed assembly upwards into the pump body. Once placed inside, tilt the pump body back up to keep all pieces.
17. Thread the packing nut into the top of the fluid body and tighten hand tight.
 18. Take the suction retainer and replace the black O-ring with a new one from the packing kit. Replace the suction ball with the new one from the kit into the suction retainer. Place the suction seat into the flat side of the ball guide, over the suction ball. Now place the white O-ring into the groove around the suction seat.
 19. Take the completed suction valve assembly and place it into the bottom of the fluid body, with the rounded side fitting inside.
 20. Take the suction seat support and place the flat side down on the suction valve assembly (threads will be facing upwards).
 21. Thread the suction nut, over the suction seat support.
 22. Tighten the packing nut (utilizing the packing nut adjustment tool) clockwise one full turn.

Replacement of Electrical Control Board

1. Remove electrical cover.
2. Disconnect sensor lead from Electrical Board.
3. Disconnect two clutch leads on Electrical Board from leads on clutch.
4. Using a 1/16" allen, loosen set screw in Pressure Control Knob and remove knob.
5. Using a 1/2" nut driver or 1/2" deep socket, remove nut from pressure control shaft. This will allow removal of electrical control board from frame.
6. Replace Electrical Board Assembly in reverse order. Adjust pressure. See Pressure Calibration of the Electrical Control Board.

Pressure Calibration of the Electrical Control Board

1. Turn "Pressure Calibration" Trim pot adjustment on electrical control board in the counter clockwise direction at least 15 revolutions.
2. Connect 5000 psi glycerin pressure gauge on outlet of pump between fluid pump and airless hose to monitor Fluid Pump Pressure.
3. Start engine and run at maximum RPM. Turn prime Valve to open (Prime) position. Turn Pressure Control Knob to maximum position (fully clockwise).
4. Using an insulated screwdriver adjust "Pressure Calibration" Trim pot by turning clockwise until the clutch engages. When the clutch engages the pump will commence Priming. When pump is primed, turn the Prime Valve to the Closed (Pressure) Position.

NOTE: The pump will begin to pressurize and the clutch will disengage at a low pressure. Continue turning the trim pot clockwise to increase pressure 3000 psi.

5. Trigger gun. The pressure should drop approximately 350-400 psi, the clutch will engage and build pressure to 3000 psi and disengage. Trigger gun several times to ensure proper pressure setting.
6. Turn Pressure Control Knob to minimum position. The clutch should disengage and pump stop moving.
7. Secure leads with tie strap.
8. Replace cover on unit. Ensure the leads are not pinched or damaged in the process of replacing covers.

Engine - Single Wire Models

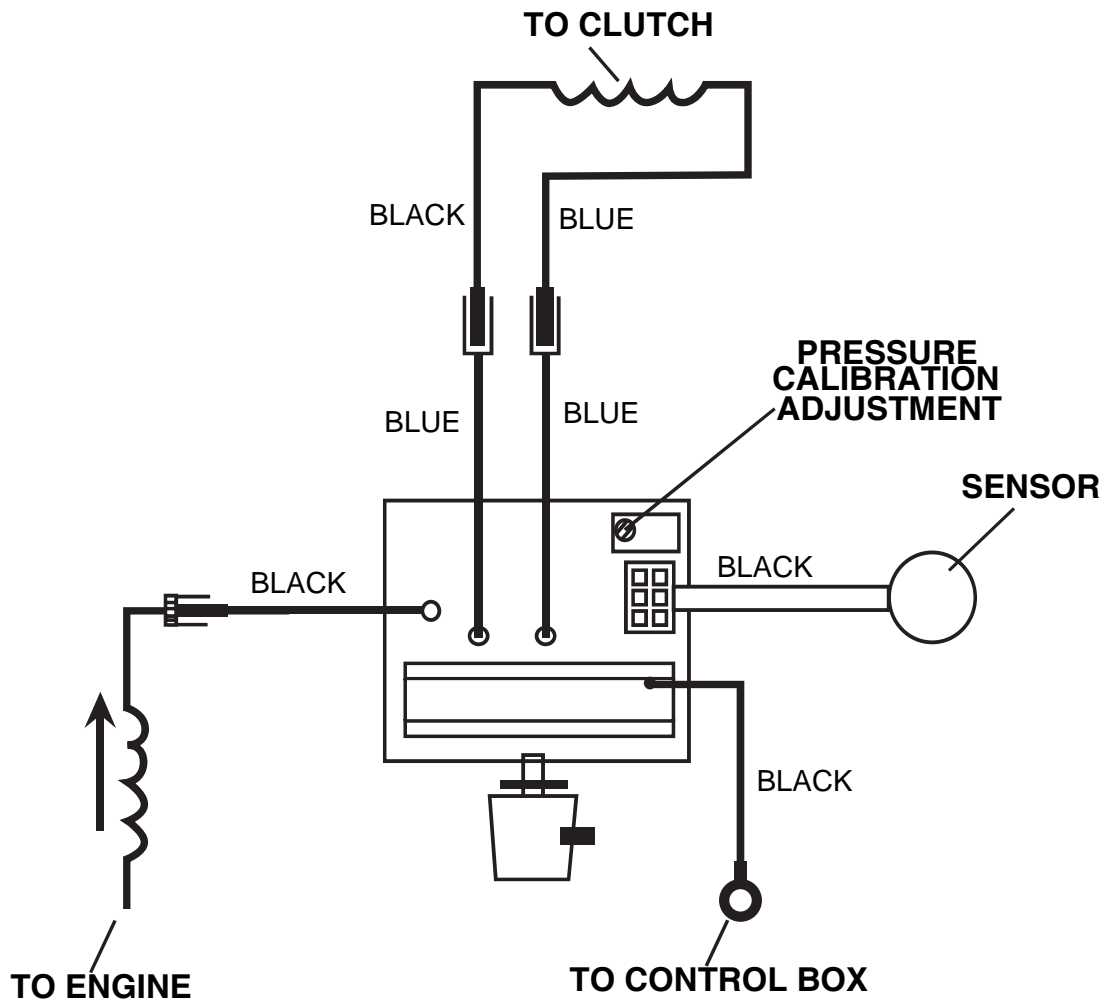

Engine - Double Wire Models:

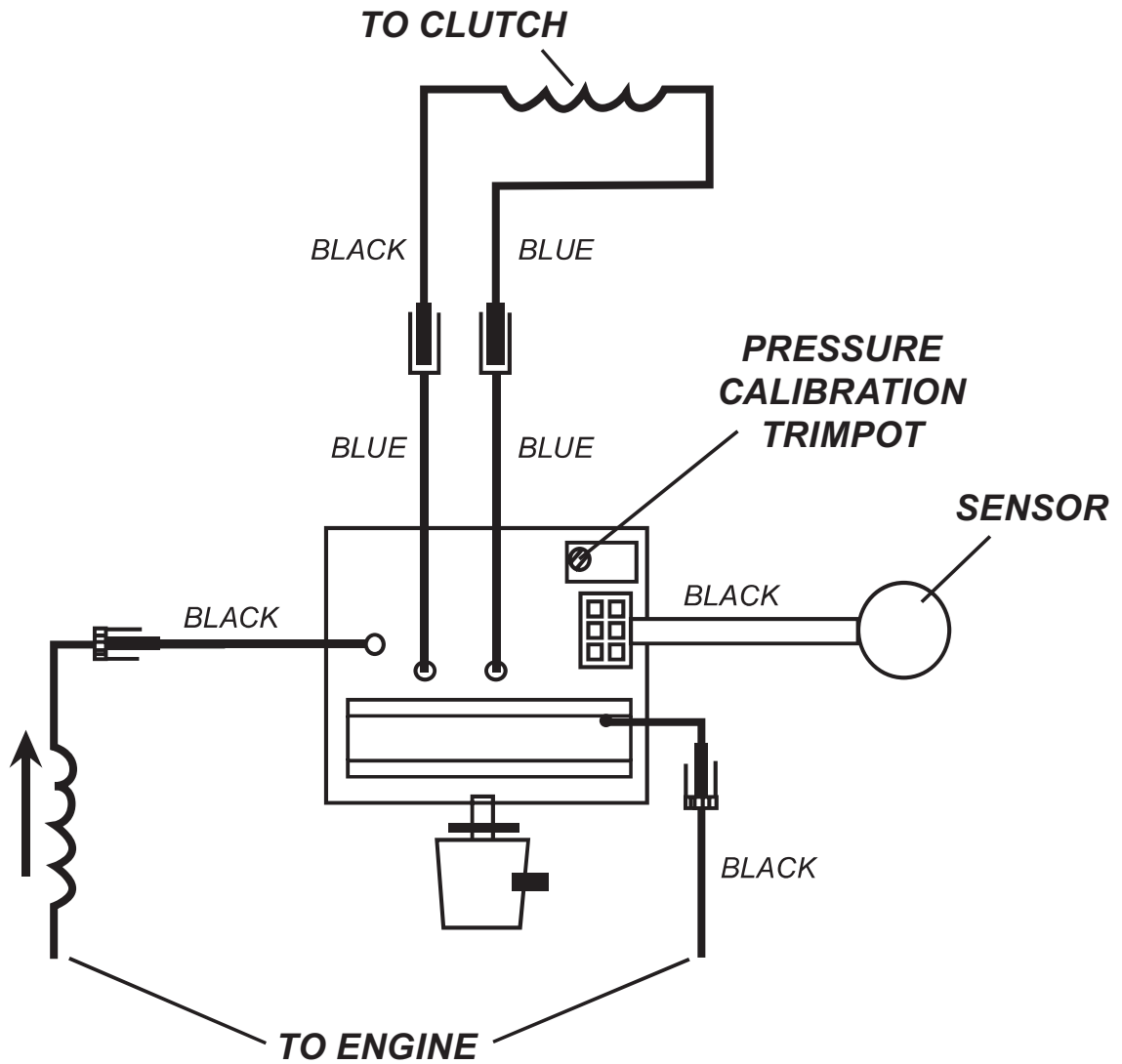

Clutch Replacement

Removing the Clutch

Refer to the following parts diagrams: Clutch Replacement, Clutch Assembly, and Power Unit Assembly

1. Remove the gear box cover by disconnecting fluid hose to the manifold filter and unscrewing the four allen head bolts.
2. **Disconnect the Fluid Pump.**
3. Pull off the spacer tubes and drop the sleeve bearing down and off. Slide the connecting rod off the gear box.
4. Remove the top cover (Power Unit Assembly, Ref. 99) by unscrewing the 6 mounting screws. Be careful not to lose the 6 matching grommets.
5. Remove the bottom cover (Power Unit Assembly, Ref. 111) by unscrewing the 2 bolts and nuts.
6. Remove the splash cover (Power Unit Assembly, Ref. 139) from the clutch brackets and spacer tubes.
7. Disconnect the two clutch wires from the electrical control board leads and clutch the spring from the spacer tube.
8. Loosen (do not remove completely) the block tensioner's set screws to detension the belt.
9. Loosen (do not remove) the four plate bolts.
10. Pull the cog belt loose from the engine shaft cog pulley and let hang loose on the clutch cog pulley.
11. Remove the two vertical bracket screws.
12. Remove the four horizontal screws throughout the gearbox plate (Clutch Replacement, Ref. 141) and lift the gear box off the machine.
13. Place gearbox in vice by gripping the flat part of the drive crank allowing the clutch assembly to face up. Use caution and not allow gearbox to swing and damage casting against vice.
14. Hold coupling screw, with 13/16" wrench, then with 5/16" allen wrench, screw differential screw out of coupling screw and gearbox shaft.
15. Remove the coupling screw from the clutch bore.
NOTE: After extended use the coupling screw can hang up inside of the clutch bore. Tapping on the side of the coupling screw and/or the use of the lightweight oil or break free product can ease the removal process. In extreme cases, screw the differential screw large thread size in, then place a washer and nut on the small thread side. This allows pulling or prying on the coupling screw in order to remove it.
16. The clutch and other components can now be slid off the gear box shaft.

Inspecting the Clutch

Inspect clutch and belt, replace as necessary.

Installing the Clutch

Refer to the following parts diagram: Power Unit Assembly.

1. With gearbox held in a vice vertically as previously described, place first spacer, and bearing, onto gearbox shaft.
2. Install snap rings, into recesses of cog pulley portion of clutch. Place cog pulley portion of clutch with cog belt attached onto shaft.
3. Place second spacer, into cog pulley portion of clutch. This spacer will rest on the first bearing, installed.
4. Insert second bearing, on top of upper snap ring.
5. Lay removable spacer on top of last bearing. If the clutch air gap is larger than .024", do not use removable spacer. Put spacer over removable spacer, if used, and top bearing.
6. Place coil portion of clutch down onto cog pulley portion of clutch and center on gearbox shaft.
7. Screw differential screw, into coupling screw and nut until 1/16" is showing. See Clutch Assembly.
8. Push coupling nut assembly, into clutch assembly until it comes to a positive stop. (Differential screw comes into contact with the threaded gearbox shaft.)
9. With 13/16" wrench on coupling screw and 5/16" allen wrench in differential screw, simultaneously with both wrenches screw coupling nut assembly into gearbox shaft by turning clockwise to 15 ft-lbs.
10. Hold coupling nut assembly and tighten differential screw to 30 ft.-lbs. This will expand the coupling assembly, thereby holding the clutch assembly to gearbox shaft. Turn clutch observing clutch gap. The pulley should turn freely with a gap of .012 to .024" between the two clutch faces. If the gap is greater than .024, remove the removable spacer. Reassemble and check gap for proper clearance.
11. Place cog belt over cog pulley portion of clutch. Set gearbox and clutch assembly on the support brackets (Power unit Assembly, Ref. 16 & 109), screw in the two vertical bracket screws (Power unit Assembly, 13 and start the four horizontal screws throughout the gearbox plate and into the back of the gearbox.
12. Slide cog belt over engine pulley.

Parts Lists

Models 4550 and 6050 Power Unit

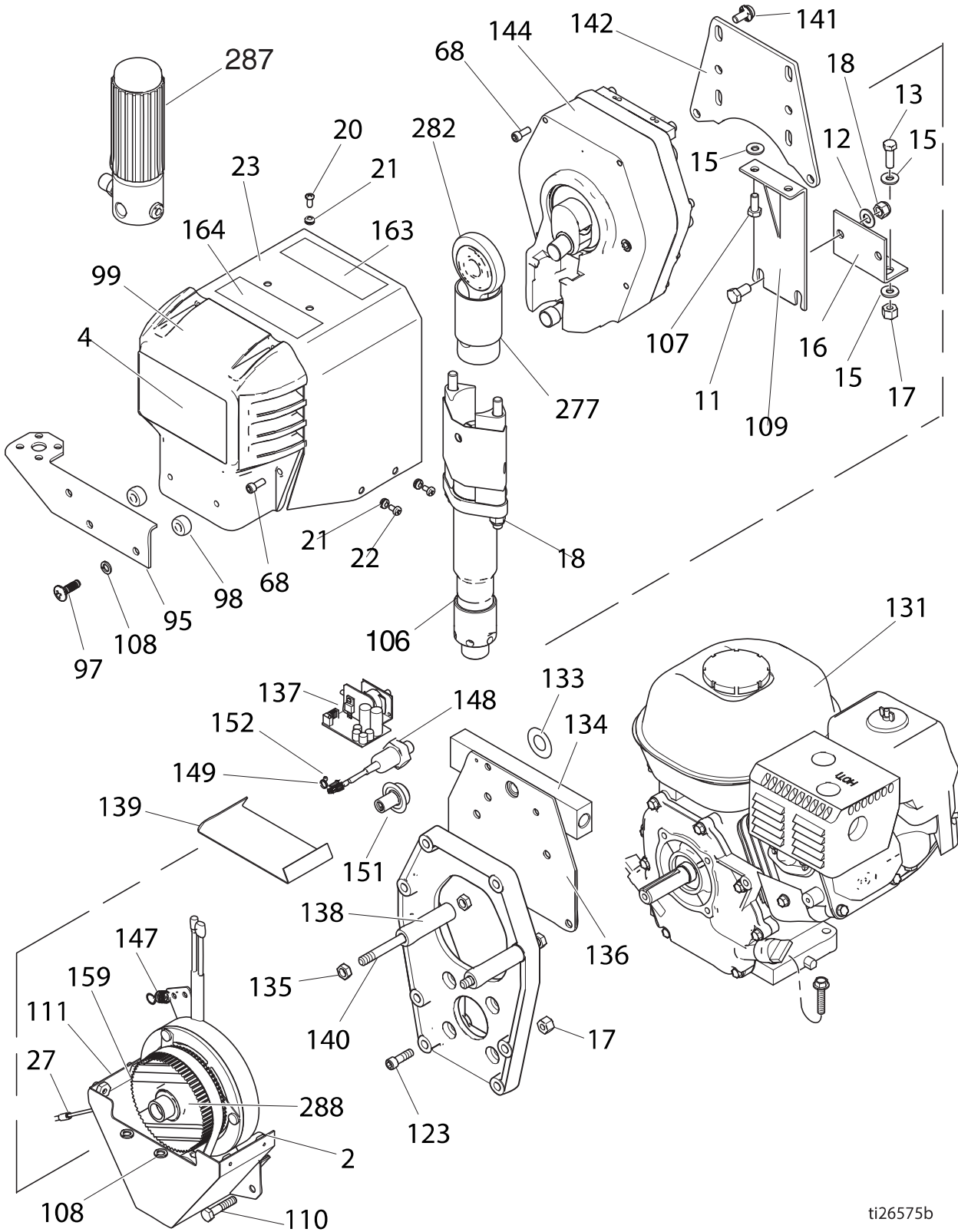

ti26575b

Parts List

Parts List				Ref.	Part	Description	Qty
				133	342520	LABEL, PRESSURE	1
				134	301253	MANIFOLD	1
				135	101448	NUT, JAM	8
2		LABEL, DESIGNATION	2	136	305064	HOLDER, MANIFOLD	1
4	342579	LABEL, FRONT (Model 4550)	1	137	865676	CONTROL, PRESSURE	1
	342580	LABEL, FRONT (Model 6050)	1	138	305046	SPACER	4
11	100469	SCREW, CAP, HEX HD	2	139	301529	COVER	1
12	140034	WASHER,.820x.4 11,.062	2	140	305047	SCREW	1
13	124227	SCREW, CAP, HEX HD	2	141	111800	SCREW, CAP, HEX HD	4
15	100527	WASHER, PLAIN	2	142	305045	PLATE, GEARBOX MOUNT	1
16	301299	PLATE,SUPPORT BOTTOM	1	144	866143	GEARBOX	1
17	110838	NUT, LOCK	6	147	136068	SPRING	1
18	101566	NUT, LOCK	2	148	331294	SENSOR	1
20	110037	SCREW, MACH, PNH	2	149	111959	PACKING,O'RING	1
21	301135	GROMMET	6	151	301523	KNOB	1
22	110637	SCREW, MACH, PANHEAD	4	152	102273	SCREW, SET SCREW	1
23	301531	COVER, TOP	1	159	301222	GEAR, SHEAVE ASSY	1
27	24E873	WIRE, CONTROL BOARD	1	163▲	342506	LABEL, WARNING	1
68	121112	SCREW, CAP, SOCKET HEAD	4	164▲	342473	LABEL, WARNING	1
95	305140	BRACKET, FILTER	1	277	301047	BEARING, SLEAVE	1
97	867534	SCREW, PH,HD, 5/16-18X1.00	2	282	301333	ROD, CONNECTING ASSY	1
98	866445	SPACER, .377 ID X.40	2	287	865627	FILTER, MANIFOLD ASSY	1
99	301320	COVER	1	288	866054	CLUTCH	1
106	866267	PISTON, PUMP	1	▲ Replacement Danger and Warning labels, tags, and cards are available at no cost.			
107	100057	SCREW, CAP, HEX HD	2				
108	100214	WASHER, LOCK	4				
109	301232	SUPPORT, TOP	1				
110	110837	SCREW,CAP, HEX HD	4				
111	305067	COVER, BOTTOM	1				
123	109031	SCREW, CAP,SCH	4				
131	114530	ENGINE, GAS	1				

Parts Lists

Gun Arm Parts

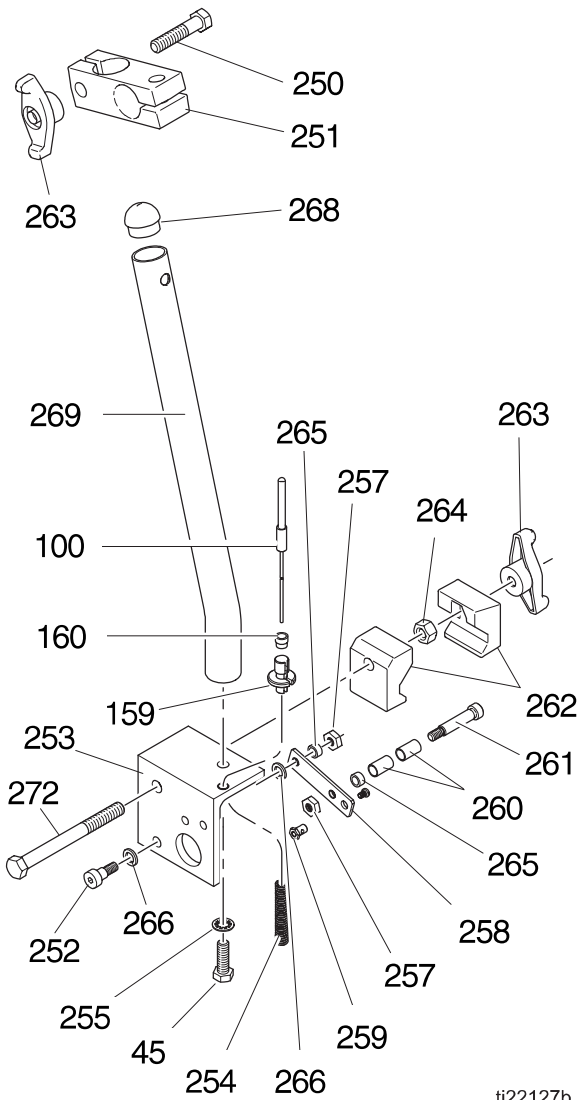

ti22127b

Ref.	Part	Description	Qty
45	124227	SCREW, cap, hex hd, 5/16-18 x 1.00	1
100	866043	CABLE assy, 115.5" (4550)	1
	866046	CABLE assy, 139.5" (6050)	1
159	305141	ADJUSTER, cable	1
160	305089	INSERT, cable	1
250	867513	SCREW, 3/8-16 x 1.75 hx hd	2
251	867653	BLOCK, swivel clamp	1
252	305158	SCREW, shoulder, socket head	1
253	305154	BRACKET, clamp	1
254	867627	SPRING, compression	1
255	100186	WASHER, lock, internal tooth	1
257	140045	NUT, hex, jam	2
258	305155	LEVER, lever - gun holder assy	1
259	305079	WIRE, swivel	1
260	305159	BEARING, sleeve bearing	2
261	866339	SCREW, shoulder screw 5/16 x 1.25	1
262	305152	CLAMP, clamp outer - casting	2
263	305157	KNOB, wing	3
264	100307	NUT, hex	1
265	305161	SPACER	2
266	305156	WASHER, flat	2
268	143027	BALL, glide	2
269	305297	HOLDER, gun	1
272	124234	SCREW, cap hex, 3/8-16x4, GR.5	1

Pump Parts

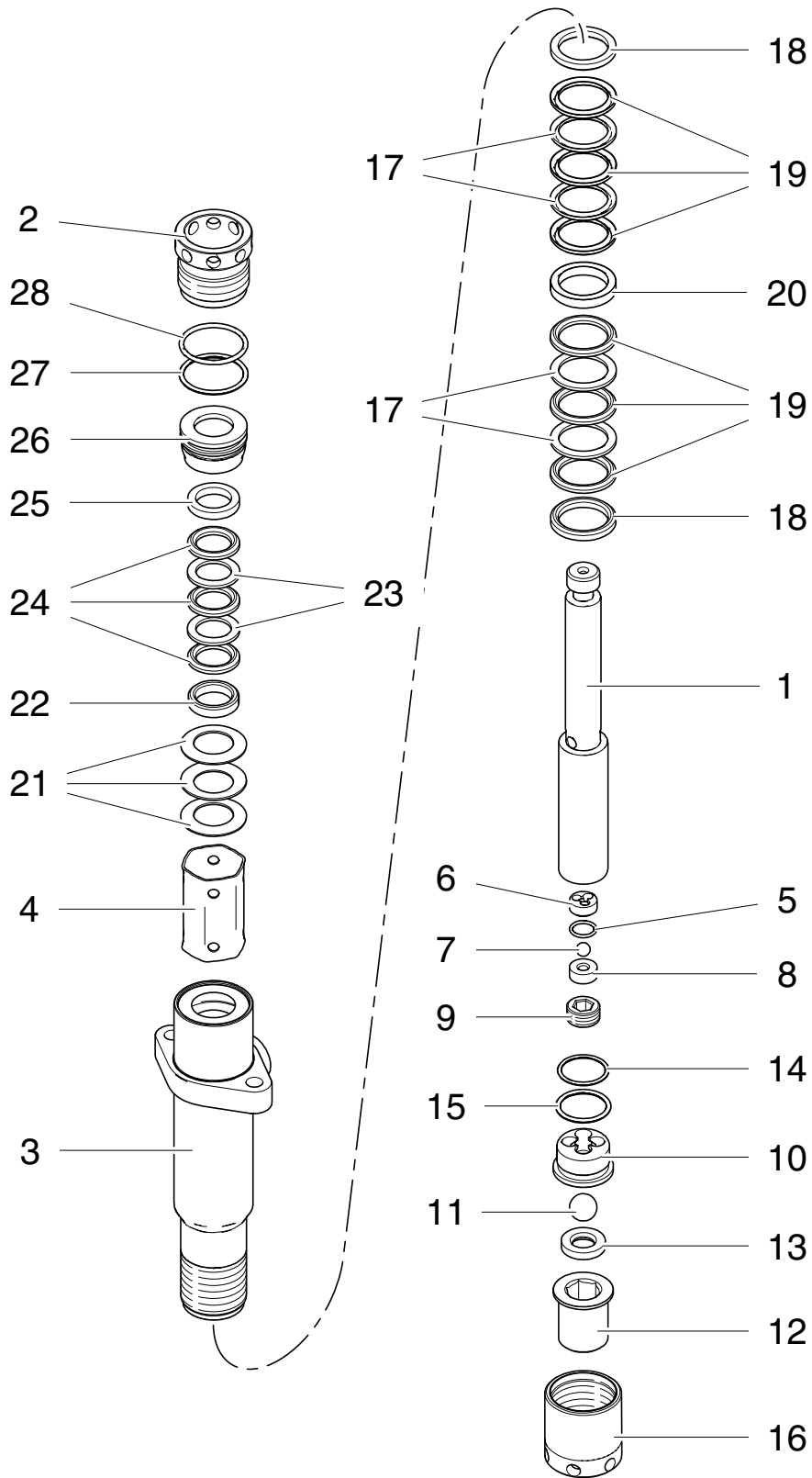

Parts Lists

Pump Parts List

Ref.	Part	Description	Qty	Ref.	Part	Description	Qty
1*		PISTON, 2.00 STROKE, SL	1	27+	126570	O-RING, 2-126, PTFE	1
2+	866056	SCREW, COLLAR	1	28+	107083	PACKING, O-RING	1
3+	866295	BODY, PUMP, MACHINING	1			+These parts are included in Repair Kit 866267	
4+	866362	SPACER, TUBE	1			* These parts are included in Repair Kit 866269	
5*+	104319	PACKING, O-RING	1				
6*+	866307	RETAINER, BALL, .3125, SL	1				
7+	867047	BALL, .3125, GR25, PISTON	1				
8+	867575	SEAT, UPPER, T.C.	1				
9*+	866274	PLUG, 3/4-20	1				
10+	866306	RETAINER, SUC-TION	1				
11+	101822	BALL, INTAKE	1				
12+	866400	SUPPORT, SUC-TION SEAT	1				
13+	867574	SEAT, T.C.	1				
14+	867390	O-RING, 5-677, PTFE	1				
15+	556562	O-RING, -121 VITON-A 75 DURO	1				
16+	866241	NUT, SUCTION	1				
17+	867689	PACKING, VEE, LEATHER	4				
18+	866018	ADAPTER, MALE, SHORT	2				
19+	867693	PACKING, V-PACK-ING(1.500/1.125)	6				
20+	866100	ADAPTER, Dou-ble, FEMALE	1				
21+	867083	SPRING, BEL-LEVILLE	3				
22+	866011	ADAPTER, MALE	1				
23+	867688	PACKING, VEE, LEATHER	2				
24+	867608	PACKNG, SEAL, 1.1 87/.810, UHWPE	3				
25+	866010	ADAPTER, FEMALE	1				
26+	866426	HOLDER, V PACK-ING	1				

Model 4550 Frame Assembly

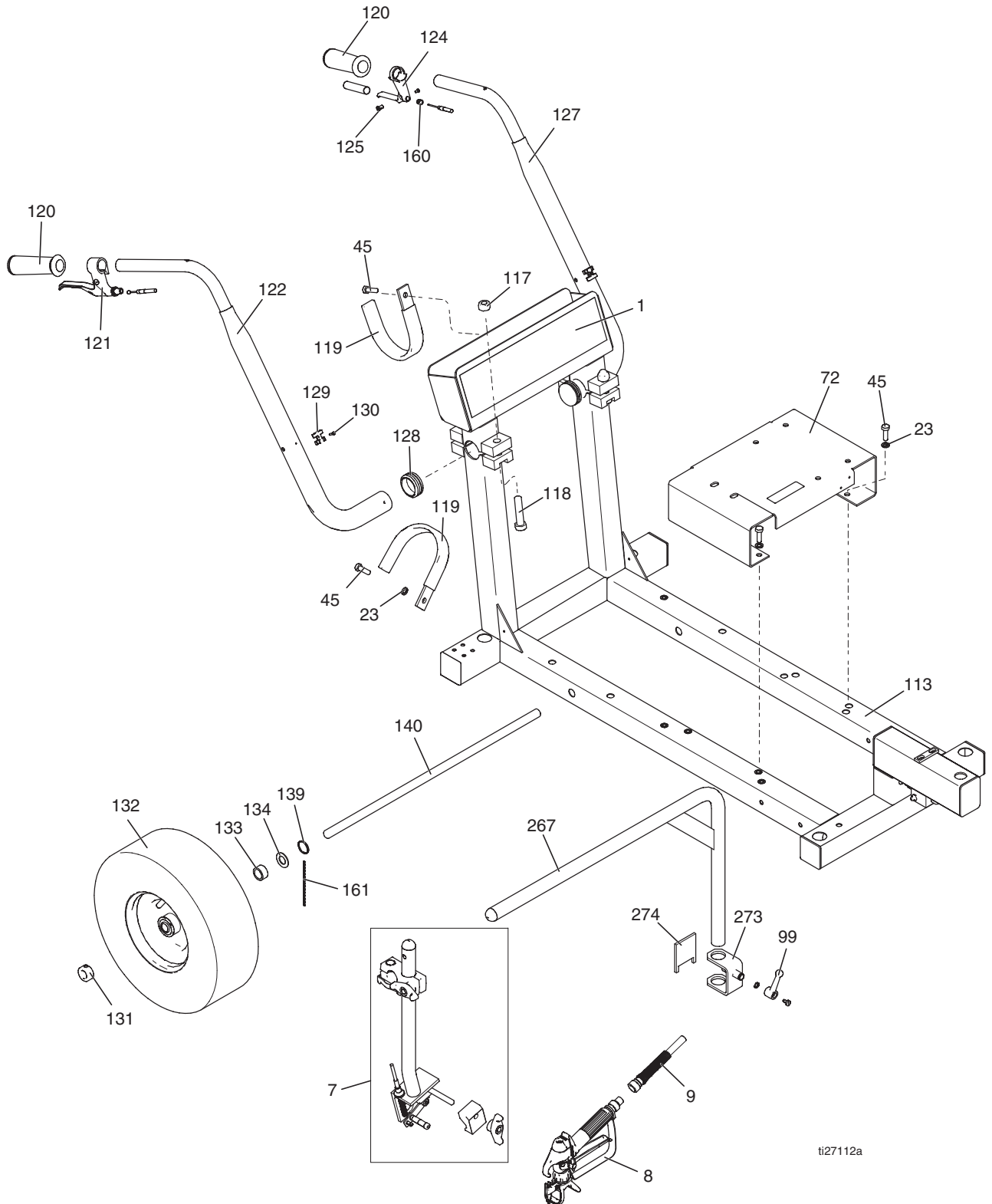

ti27112a

Parts Lists

Parts List

Parts List				Ref.	Part	Description	Qty
				128	867419	CAP, tube, round	2
				129	867638	STRAP, two channel	2
1	342582	LABEL, handle	1	130	867487	SCREW, #4-40X. 50 log flat	2
7	305150	HOLDER, gun assy, (includes #121)	1	131	143029	COLLAR, screw set	4
8	289316	GUN,500,4 Finger (models 305403, 305404)	1	132	301166	WHEEL, pneumatic	2
	24H289	GUN,009, Europe (models 865937, 865938)	1	133	305039	SPACER,.75" x.50"	2
9	865675	HOSE, paint hose 3/8 x 50'	1	134	867732	WASHER, wave washer for 5/8 axle	2
23	100214	WASHER, lock	6	139	136133	RING, retaining lg	1
45	124227	SCREW, cap, hex HD, 5/16-18 x 1	9	140	866026	AXLE,5/8 x 21.81" lg	1
99	305044	HANDLE, adjustable	1	160	305089	INSERT, cable	2
113	305395	FRAME, w/swivel	1	161	136131	CHAIN, sash #8 x 7" lg	1
117	867318	NUT, locking	4	267	139353	ARM, sg short	1
118	867780	SCREW, hex hd	4	273	867125	CLAMP, arm	1
119	123979	HOOK, hose	3	274	305108	PLATE, gun arm	1
120	123938	GRIP, handle	2	275▲	222385	LABEL, safety,warning (not shown)	1
121	866520	LEVER, assembly	1				
122	305315	HANDLE, right	1				
124	305105	LEVER,128 right hand	1				
125	305079	WIRE, swivel	1				
127	305314	HANDLE, left	1				

▲ Replacement Danger and Warning labels, tags, and cards are available at no cost.

Model 4550 Swivel Wheel Assembly

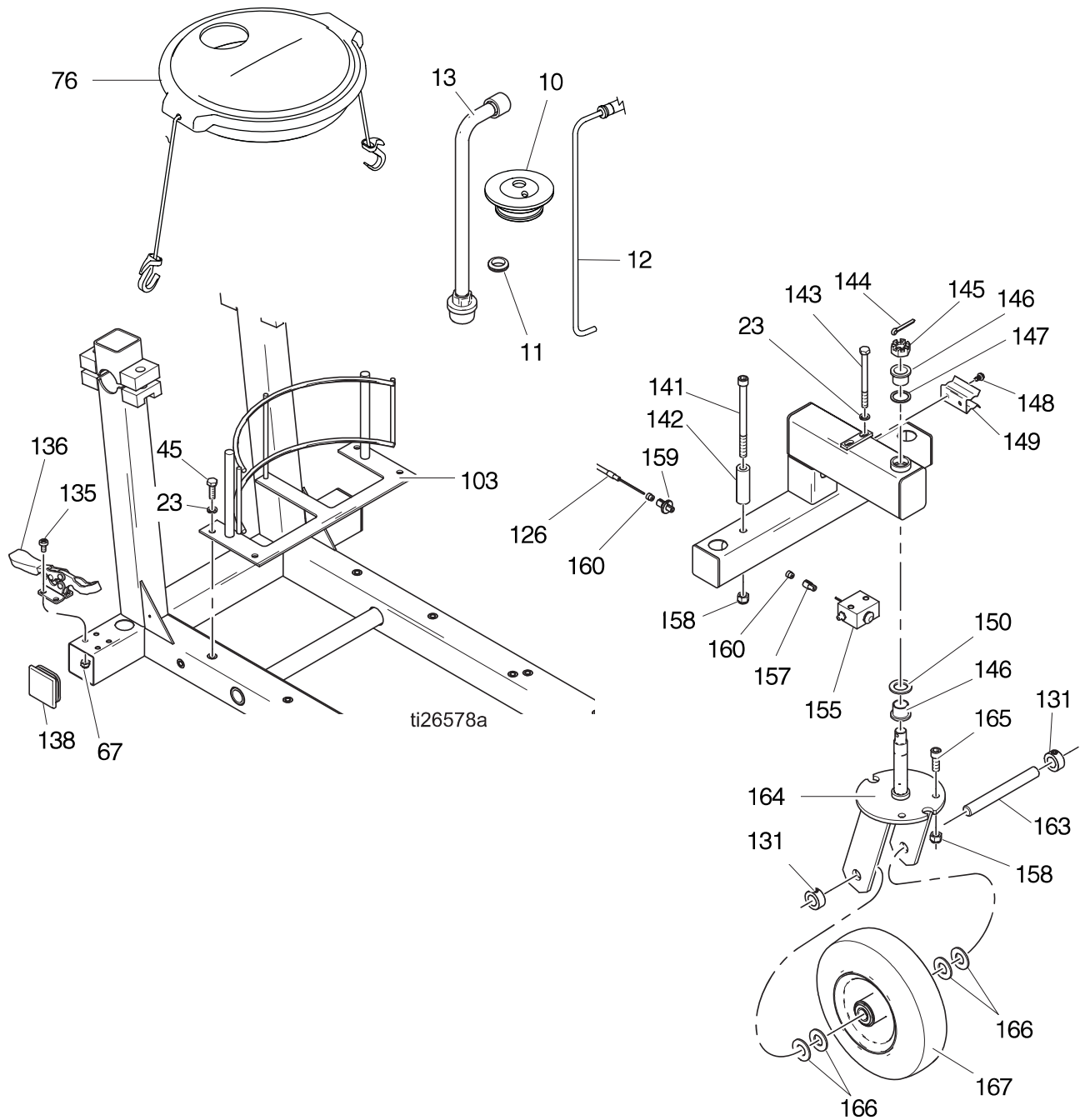

Parts Lists

Parts List

Parts List				Parts List			
Ref.	Part	Description	Qty	Ref.	Part	Description	Qty
				142	865010	SPACER, tube	2
				143	867539	SCEW, 5/16-18 x 3.75 hex hd	2
10	278722	GASKET, pail	1	144	867139	PIN, cotter	1
12	17D469	HOSE, drain	1	145	867021	NUT, hex slotted, 5/8-18	1
13	17D468	HOSE, hose suction assy. (includes #10)	1	146	867230	BEARING, flanged	2
23	100214	WASHER, lock	10	147	145006	WASHER, plain	1
45	124227	SCREW, cap, hex hd, 5/16-18 x 1.00	10	148	139335	SCREW, self drilling	2
67	102040	NUT, lock, hex	4	149	867622	CLAMP, spring	1
74	136231	TURNBUCKLE 12-1/4 max (not shown)	1	150	154628	WASHER	1
76	24U241	KIT, pail cover	1	155	305160	KIT, swivel lock assy.	1
131	143029	COLLAR, screw, set	4	157	305261	CABLE, holder	1
135	113783	SCREW, machine, PN HD	4	158	101566	NUT, lock	4
136	17E109	CLAMP, brake, hold down	1	159	305141	ADJUSTER, cable	1
138	867107	CAP, tube, square	1	160	305089	INSERT, cable	2
141	867520	SCREW, cap, socket head	2	163	136230	AXLE, front	1
				164	305253	CLAMP, swivel	1
				165	C19837	SCREW, cap, socket hd	2
				166	100841	WASHER, plain 5/8	4
				167	119542	WHEEL, small	1

Parts Lists

Parts List

Ref	Part	Description	Qty
1	342582	LABEL, Sure Stripe Handle	1
5	113664	SCREW, cap hex head	4
6	301202	BRACKET, plate	1
7	305393	HOLDER, gun S66050	1
8	289316	GUN,500, 4 finger	1
9	865675	HOSE, 3/8" x 50'	1
10	112405	NUT, lock	2
11	111020	WHEEL, pneumatic	2
12	140034	WASHER, .820x.411x.062	2
13	100454	SCREW, mach. pan head	1
16	100527	WASHER, plain	8
19	110838	NUT, lock	5
20	101566	NUT, lock	1
23	100214	WASHER, lock	2
45	124227	SCREW, cap, hex head	3
113	305050	FRAME, weldment	1
117	867318	NUT, lock	4
118	867780	SCREW, hex head	4
119	123979	HOOK, hose	3
120	123938	GRIP, handle	2
121	866520	LEVER, assembly 2ea. on model 305307	1
122	305314	HANDLE, right	1
124	305105	LEVER, right hand	1
125	305079	WIRE, swivel	1
127	305315	HANDLE, left	
128	867419	CAP, tube	2
129	867638	STRAP, two channel	2
130	867487	SCREW, #4-40x.50 flat	2
160	305089	INSERT, cable	2
267	139353	ARM, sq, short	1
273	867125	CLAMP, arm	1
274	305108	PLATE, gun arm	1
275	114648	CAP, dust	2
278	305052	AXLE	1

Model 6050 Swivel Wheel Assembly

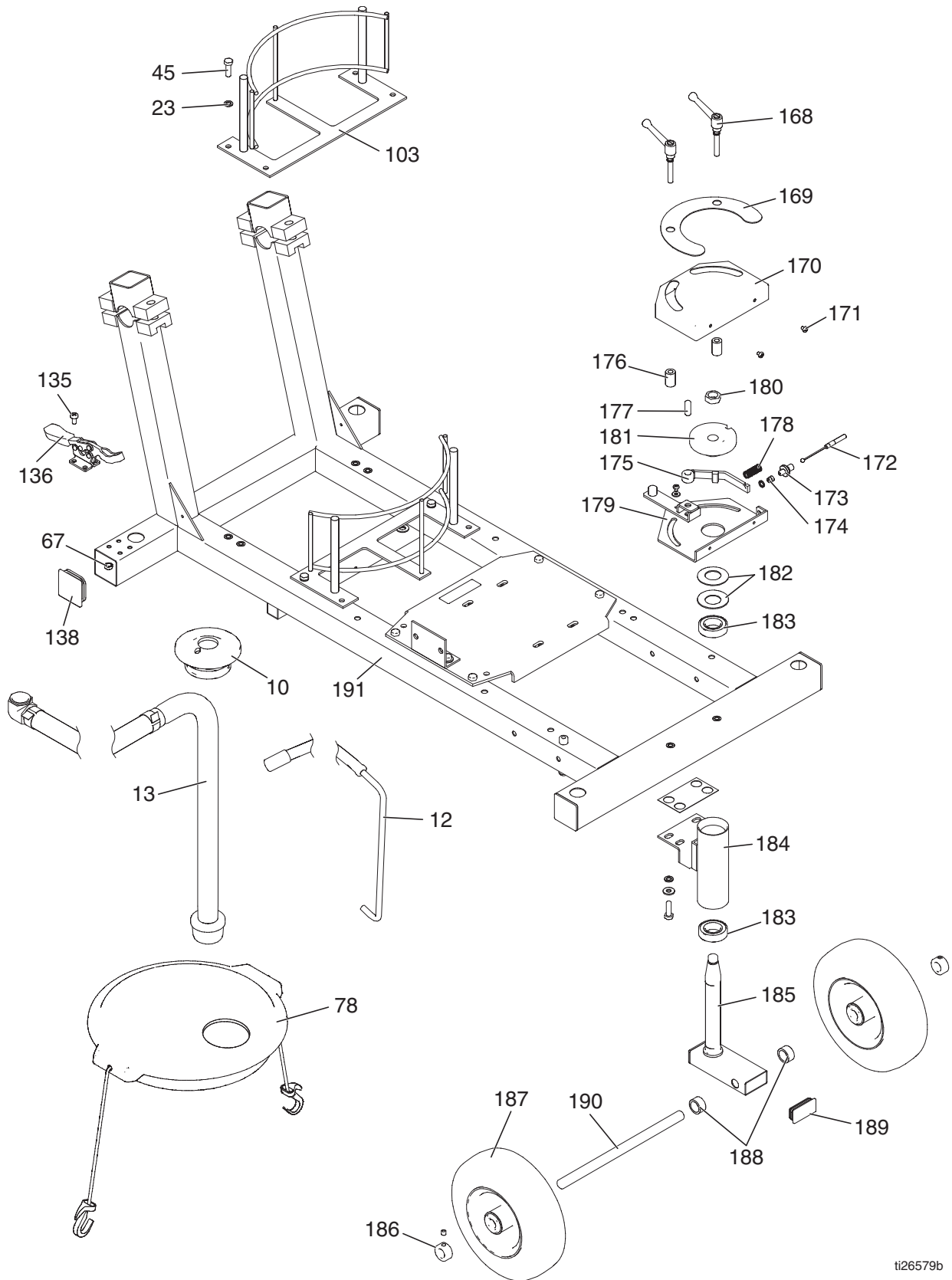

ti26579b

Parts Lists

Parts List

Parts List				Qty
Ref.	Part	Description	Qty	
				171 116807 SCREW 3
				172 866048 CABLE, assy85" lg 1
				173 305141 CABLE ADJUSTER 1
10	278622	GASKET, pail	1	174 305089 CABLE INSERT 2
12	17D469	HOSE, drain	1	175 305081 LEVER 1
13	331290	HOSE, hose suction	1	176 305027 SPACER 2
		assy. (includes #10)		177 867170 DOWEL PIN 1
23	100214	WASHER, lock	10	178 305032 SPRING 1
45	124227	SCREW, cap, hex	10	179 305031 WELDMENT, Base 1
		hd,5/16-18 x 1.00		Lock
67	102040	NUT, lock, hex	4	180 100155 NUT, Jam 1
78	24U241	KIT, pail cover	1	181 305025 SWIVEL, Lock 1
103	16D109	BRACKET, pail	2	182 305028 SPRING, Belleview 2
		support		183 301036 BEARING 2
135	113783	SCREW, machine,	4	184 305023 SWIVEL BODY 1
		PN HD		185 305024 KING PIN 1
136	305185	CLAMP, brake, hold	1	186 143029 COLLAR, Set Screw 2
		down		187 119542 WHEEL 2
138	867107	CAP, tube, square	1	188 305039 SPACER 2
168	305020	HANDLE,adjustable	2	189 305037 CAP, tube, square 1
		Handle 3/8 X 1		190 305038 AXLE 1
169	305091	SEAL	1	191 305050 FRAME 1
170	305049	COVER-LOCK	1	

Pressure Control Wiring Diagram

Engine - Single Wire Models:

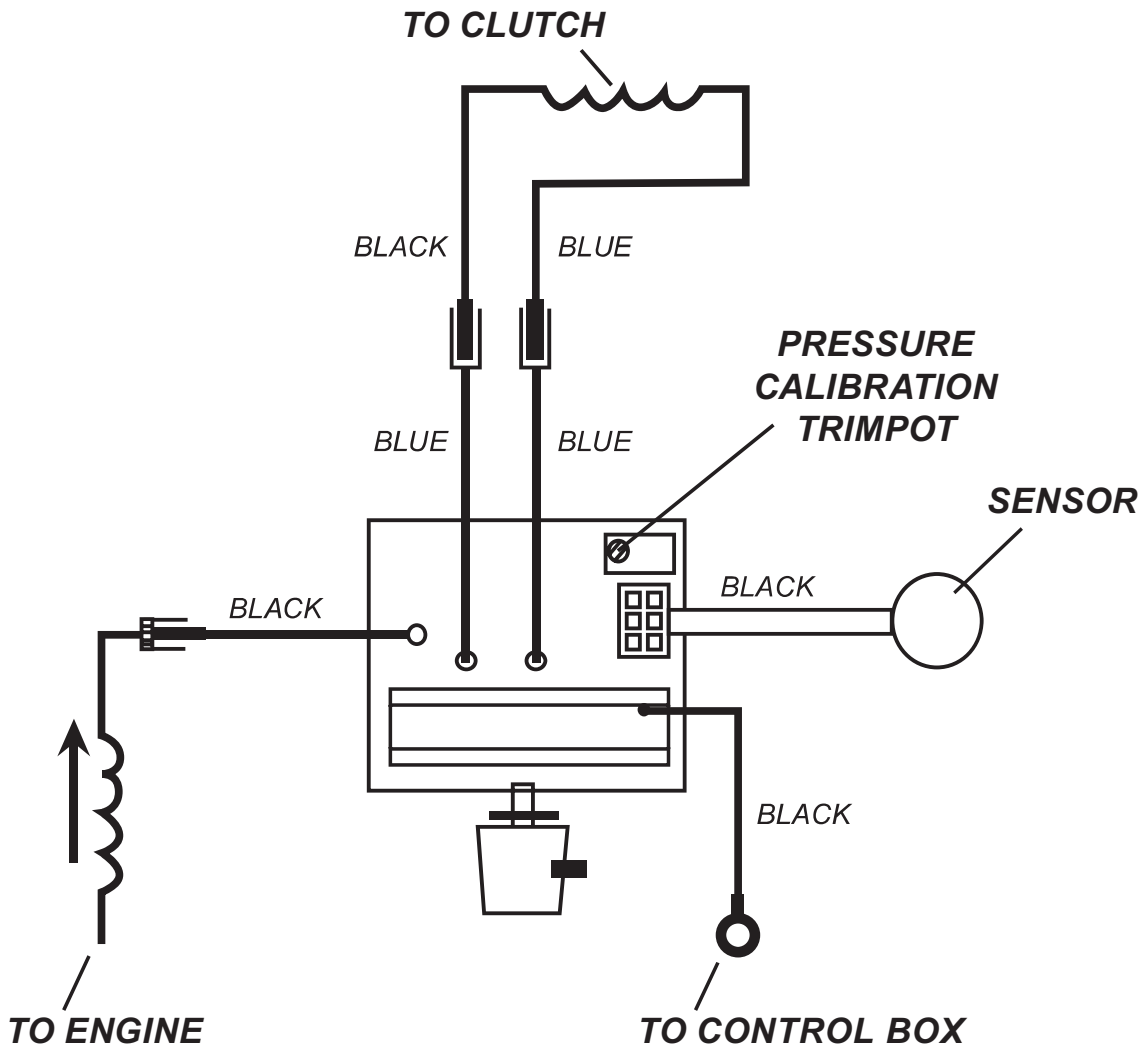

Ref.	Part	Description	Qty
3	114530	ENGINE, gas	1
13	305277	ENCLOSURE, mach	1
17	865676	KIT, control, pressure (includes 246, 247)	1
209	331294	SENSOR, assy	1
246	117316	CONNECTOR, bullet M	1
247	867095	CONNECTOR, bullet F	1
248	24E873	WIRE, control board	1
249	24E874	WIRE, control board	1

Parts Lists

Pressure Control Wiring Diagram

Engine - Double Wire Models:

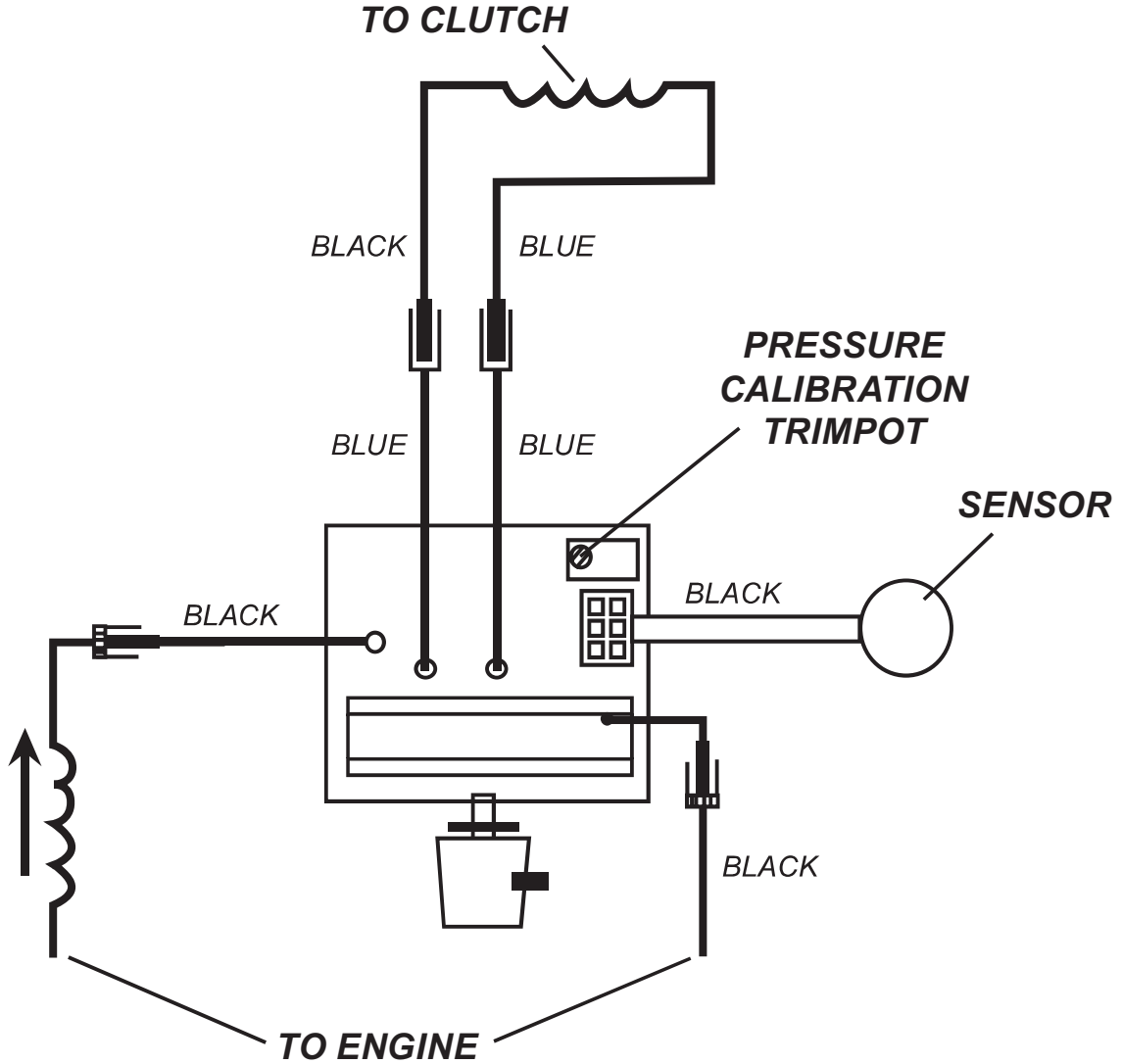

Ref	Part	Description	Qty
3	114530	ENGINE, gas	1
13	305277	ENCLOSURE, mach	1
17	865676	KIT, control, pressure (includes 246, 247)	1
209	331294	SENSOR, assy	1
246	117316	CONNECTOR, bullet M	1
247	867095	CONNECTOR, bullet F	1
248	24E873	WIRE, control board	1
249	24E874	WIRE, control board	1

Technical Data

SureStripe 4550 (Model 305403) (1 Gun)

Maximum working pressure	3300 psi (22.8 MPa, 228 bar)
Maximum delivery gpm (lpm)	1.50 (5.70)
Maximum tip size	0.035 in.
Motor	Honda GX160
Weight	215 lbs

SureStripe 4550 (Model 305404) (2 Gun)

Maximum working pressure	3300 psi (22.8 MPa, 228 bar)
Maximum delivery gpm (lpm)	1.50 (5.70)
Maximum tip size	0.029 in.
Motor	Honda GX160
Weight	215 lbs

SureStripe 6050 (Model 305305) (1 Gun)

Maximum working pressure	3300 psi (22.8 MPa, 228 bar)
Maximum delivery gpm (lpm)	1.70 (6.4)
Maximum tip size	0.029 in.
Motor	Honda GX160
Weight	242 lbs

SureStripe 6050 (Model 305307) (2 Gun)

Maximum working pressure	3300 psi (22.8 MPa, 228 bar)
Maximum delivery gpm (lpm)	1.70 (6.4)
Maximum tip size	0.029 in.
Motor	Honda GX160
Weight	242 lbs

Airlessco Standard Warranty

Airlessco warrants all equipment referenced in this document which is manufactured by Airlessco and bearing its name to be free from defects in material and workmanship on the date of sale to the original purchaser for use. With the exception of any special, extended, or limited warranty published by Airlessco, Airlessco will, for a period of twelve months from the date of sale, repair or replace any part of the equipment determined by Airlessco to be defective. This warranty applies only when the equipment is installed, operated and maintained in accordance with Airlessco's written recommendations.

This warranty does not cover, and Airlessco shall not be liable for general wear and tear, or any malfunction, damage or wear caused by faulty installation, misapplication, abrasion, corrosion, inadequate or improper maintenance, negligence, accident, tampering, or substitution of non-Airlessco component parts. Nor shall Airlessco be liable for malfunction, damage or wear caused by the incompatibility of Airlessco equipment with structures, accessories, equipment or materials not supplied by Airlessco, or the improper design, manufacture, installation, operation or maintenance of structures, accessories, equipment or materials not supplied by Airlessco.

This warranty is conditioned upon the prepaid return of the equipment claimed to be defective to an authorized Airlessco distributor for verification of the claimed defect. If the claimed defect is verified, Airlessco will repair or replace free of charge any defective parts. The equipment will be returned to the original purchaser transportation prepaid. If inspection of the equipment does not disclose any defect in material or workmanship, repairs will be made at a reasonable charge, which charges may include the costs of parts, labor, and transportation.

THIS WARRANTY IS EXCLUSIVE, AND IS IN LIEU OF ANY OTHER WARRANTIES, EXPRESS OR IMPLIED, INCLUDING BUT NOT LIMITED TO WARRANTY OF MERCHANTABILITY OR WARRANTY OF FITNESS FOR A PARTICULAR PURPOSE.

Airlessco's sole obligation and buyer's sole remedy for any breach of warranty shall be as set forth above. The buyer agrees that no other remedy (including, but not limited to, incidental or consequential damages for lost profits, lost sales, injury to person or property, or any other incidental or consequential loss) shall be available. Any action for breach of warranty must be brought within two (2) years of the date of sale.

AIRLESSCO MAKES NO WARRANTY, AND DISCLAIMS ALL IMPLIED WARRANTIES OF MERCHANTABILITY AND FITNESS FOR A PARTICULAR PURPOSE, IN CONNECTION WITH ACCESSORIES, EQUIPMENT, MATERIALS OR COMPONENTS SOLD BUT NOT MANUFACTURED BY Airlessco. These items sold, but not manufactured by Airlessco (such as electric motors, switches, hose, etc.), are subject to the warranty, if any, of their manufacturer. Airlessco will provide purchaser with reasonable assistance in making any claim for breach of these warranties.

In no event will Airlessco be liable for indirect, incidental, special or consequential damages resulting from Airlessco supplying equipment hereunder, or the furnishing, performance, or use of any products or other goods sold hereto, whether due to a breach of contract, breach of warranty, the negligence of Airlessco, or otherwise.

FOR AIRLESSCO CANADA CUSTOMERS

The Parties acknowledge that they have required that the present document, as well as all documents, notices and legal proceedings entered into, given or instituted pursuant hereto or relating directly or indirectly hereto, be drawn up in English. Les parties reconnaissent avoir convenu que la rédaction du présente document sera en Anglais, ainsi que tous documents, avis et procédures judiciaires exécutés, donnés ou intentés, à la suite de ou en rapport, directement ou indirectement, avec les procédures concernées.

TO PLACE AN ORDER OR FOR SERVICE, contact your Airlessco distributor,
or call 1-800-223-8213 to identify the nearest distributor.

*All written and visual data contained in this document reflects the latest product information available at
the time of publication.*

Airlessco reserves the right to make changes at any time without notice.

For patent information, see www.graco.com/patents

Original Instructions. This manual contains English. *MM 3A2702A*

GRACO INC. P.O. BOX 1441 MINNEAPOLIS, MN 55440-1441

Copyright 2015, Airlessco Inc. All Airlessco Manufacturing locations are is registered to ISO 9001

www.airlessco.com
Revision A October 2015